

M.A. Selmon Company, Inc
4 Oxford Rd.
Milford, CT 06460
(203) 377-3525
<http://www.maselmon.com/>



red-y industrial series product information

Thermal Mass Flow Meters and Controllers for Gases with IP67 & Ex Protection

High accuracy for heavy duties:

Mass Flow Meters & Controllers with IP67 & Ex Protection

**Reliable technology and industry standard interfaces for rough environments:
Our tried and tested thermal mass flow meters and controllers for gases now available
as IP67/NEMA 6 version.**

Accurate measurement

The devices offer high accuracy and a wide dynamic range.

2 instrument versions:
"Standard" and "Hi-Performance"

Accuracy up to $\pm 0.3\%$ of full scale + $\pm 0.5\%$ of reading

Turndown ratio 1 : 100

Extended turndown ratio on request

Analog & digital: 2 in 1



The flow meters & controllers make use of the latest CMOS technology and have a digital (Modbus RTU) and analog interface as standard

IP67/NEMA 6 protection



The instruments offer IP67/NEMA 6 protection against solid particles and water

ATEX certification



red-y industrial devices come along with ATEX certification (Category 3/Zone 2 & 22)

Multiple connections



The industrial series are available with different connection types: Cable gland with compression fitting or optional M12 plug on top



Options

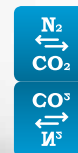

Multigas device

A device can be used for up to 10 different gases or gas mixtures



Profibus

The instruments are available with Profibus interface: DP-V0 & DP-V1 protocols

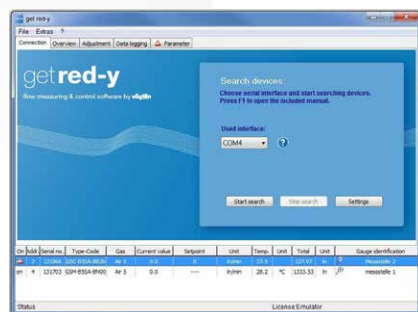

Setup tool "get red-y"

Efficient device setup with the free "get red-y" software:

- » **Service tool for remote maintenance**
- » **Switch gas type**
- » **Switch measurement units**
- » **Adjust control parameters**

3-year warranty*



High-quality components ensure long and trouble-free operation

*does not apply to calibration, options and accessories

Available connections “red-y industrial series”

Cable gland (standard)



Cable gland with optional Profibus



M12 plug (option)



M12 plug with optional Profibus



Dimensions “red-y industrial series”

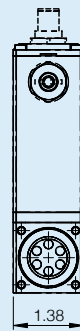
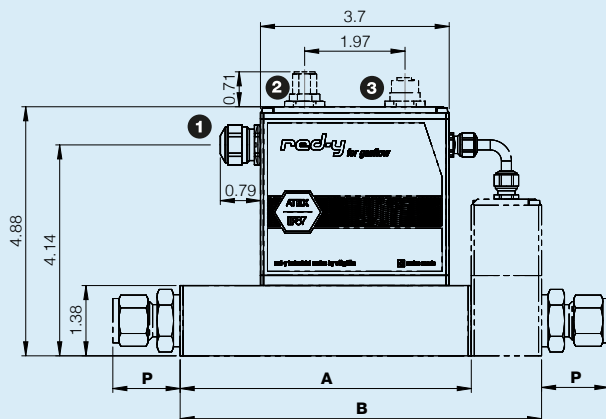

Type/Body	Length (inch)		Length of fitting
	A	B	P
GIM/¼" (MFM)	3.7	–	We offer a range of different inlet/outlet fittings. See document 329-2092_en_fittings.pdf for types and dimensions
GIM/½" (MFM)	5.7	–	
GIC/¼" (MFC)	–	5.28	
GIC/½" (MFC)	–	7.09	
GIC/½" (MFC) double valve	–	7.8	

Electrical Connection

- 1 Cable gland / cable diameter 0.236-0.315 inch
- 2 M12 connector A-Coding 8pol male
- 3 M12 connector B-Coding 5pol female

Technical Data “red-y industrial series”

Instrument types



industrial meter GIM
Thermal mass flow meter



industrial controller GIC
Thermal mass flow controller



industrial controller GIE
Thermal mass flow controller with external valve

Instrument versions

“Standard”

The economic solution

Accuracy: ± 1.0% of full scale*

Turndown ratio: 1 : 50

“Hi-Performance”

With highest accuracy and turndown ratio

(available for GIM < 200 SLPM /

GIC < 150 SLPM (air))

Accuracy: ± 0.3% of full scale + ± 0.5% of reading*

Turndown ratio: 1 : 100

*An additional error of ±0.25% may apply for analogue signals

Measuring ranges

(Air/Full scale freely selectable)

red-y industrial meter GIM

Meter

Type/Body

GIM/¼"

GIM/½"

Measuring range (air)

from 0 ... 27 SCCM

from 0 ... 65 SLPM

to 0 ... 64 SLPM

to 0 ... 480 SLPM

red-y industrial controller GSC

controller

GIC/¼"

GIC/½"

from 0 ... 27 SCCM

from 0 ... 65 SLPM

to 0 ... 64 SLPM

to 0 ... 480 SLPM

Performance data

Media (real gas calibration)

Air, O₂, N₂, He, Ar, CO₂, H₂, CH₄, C₃H₈ (other gases and gas mixtures on request)

Response time

Meter: 50 ms; Controller: 150 ms

Repeatability

± 0.2% of full scale

Longterm stability

< 1% of measured value / year

Power supply

24 Vdc (18 – 30 Vdc), 15 Vdc on request

Current consumption

Meter: max. 100 mA; Controller: max. 250 mA (except GIE)

Operation pressure

3 - 160 psia (0.2 - 11 bara)/GIC with valve type 4.5 and 8: max. 120 psia (8 bara)

Temperature (environment/gas)

32 - 122°F (0 – 50°C)

Pressure sensitivity

<0.014%/psi (<0.2%/bar) of reading (typical N₂)

Temperature sensitivity

<0.012% FS measuring range type per 1°F (<0.025% per 1°C)

Warm-up time

< 1 sec. for full accuracy

Materials

Body

Stainless steel 316L (see operating instructions for wetted parts)

Electronic Housing

Aluminum

Seals

EPDM (FDA), optional FKM

Integration & Installation

In- /Output signals analog

0-20 mA, 4-20 mA, 0-5 V, 1-5 V, 0-10 V, 2-10 V

In- /Output signals digital

RS-485; Modbus RTU 2 wire (Slave); LabView-VIs available / Option: Profibus DP-V0, DP-V1

Process connection

G¼" (BSPP* female) up to 64 SLPM, G½" (BSPP* female) up to 480 SLPM

*British Standard Pipe Parallel

Inlet section

None required

Electrical connection

Cable gland with compression fitting / Option: M12 plug (DIN-standard)

(both connection IP67 protected)

Mounting orientation

All orientations are possible. We recommend horizontal mounting.

Please contact the manufacturer for further information.

Safety

Test pressure

240 psia (16 bara)

Leak rate

< 1 x 10⁻⁶ mbar l/s He

Environmental protection

IP67 (conforms to NEMA 6)

EMC

CE EN 61326-1

ATEX Certification

Ex II 3G nA IIC T4 Gc (Category 3/Zone 2) Ex II 3D Ex tc IIIC T100°C Dc (Category 3/Zone 22)

Type code “red-y industrial series”

Instrument type		red-y industrial series (Gas)		G I		
Function	Meter				M	
	Controller				C	
	Controller with external valve				E	
Full scale of measuring range (air)	Divider A, up to 640 SCCM, ¼" Body				A 9	
	Divider B, up to 6,400 SCCM, ¼" Body				B 9	
	Divider C, up to 64 SLPM, ¼" Body				C 9	
	Divider D, up to 480 SLPM, ½" Body				D 9	
Instruments version	Standard (±1.0% full scale, 1 : 50)				S	
	Hi-Performance (±0.3% full scale, ±0.5% reading, 1 : 100)				T	
	Customer-specific / OEM				K	
Connection/Materials (body, seals)	Cable gland/Stainless steel/EPDM (FDA)**				S	
	M12 plug/Stainless steel/EPDM (FDA)				T	
	Cable gland/Stainless steel/FKM				U	
	M12 plug/Stainless steel/FKM				V	
	Customer-specific / OEM				K	
Analog signals (output)	Current 4-20 mA**				B	
	Current 0-20 mA				C	
	Voltage 0-5 V				D	
	Voltage 1-5 V				E	
	Voltage 0-10 V				F	
	Voltage 2-10 V				G	
	Customer-specific / OEM				K	
Analog signals (input)	Current 4-20 mA**				B	
	Current 0-20 mA				C	
	Voltage 0-5 V				D	
	Voltage 1-5 V				E	
	Voltage 0-10 V				F	
	Voltage 2-10 V				G	
	Not defined				N	
Customer-specific / OEM				K		
Control valve (integrated)	Type 0.1					2 1
	Type 0.2					2 2
	Type 0.5					2 3
	Type 1.2					2 6
	Type 4.5					1 2
	Type 8.0					1 3
	Valve mounted					9 5
	Customer-specific / OEM					9 9
	No valve					0 0
	Type code					G I - -

**standard

Available types of fittings (additional fittings on request)

Compression			Push-in for Polytube			VCO® & VCR® Alternatives		
Type	Body Size	max. flow (SLPM)	Type	Body Size	max. flow (SLPM)	Type	Body Size	max. flow (SLPM)
1/8" SS	¼"	5	1/4" Brass	¼"	50	1/4" SS	¼"	50
1/4" SS	¼"	50	6mm Brass	¼"	50	1/2" SS	½"	480
1/4" Brass	¼"	50	8mm Brass	¼"	64	VCO® & VCR® are registered Trademarks of Swagelok		
6 mm SS	¼"	50	3/8" Brass	½"	300			
8 mm SS	¼"	50	1/2" Brass	½"	480			
3/8" SS	½"	300	12mm Brass	½"	480			
3/8" Brass	½"	300						
1/2" SS	½"	480						
1/2" Brass	½"	480						
8 mm SS	½"	300						
12 mm SS	½"	480						

M.A. Selmon Company, Inc
4 Oxford Rd.
Milford, CT 06460
(203) 377-3525
<http://www.maselmon.com/>



Vogtlin Massflow USA

8809 Industrial Drive | Franksville, WI 53126

Phone 800-850-6110 | Fax: 262-884-9810

info@vogtlinusa.com | www.vogtlinusa.com

vögtlin 
massflow