



INSTALLATION INSTRUCTIONS

TYPES 123 AND 123-3 LOW WATER CONTROLS

LISTED AS STANDARD BY UNDERWRITERS' LABORATORIES INC.

MOUNTING

Install control so that lower part of float casting designated as "C-C" (illustration No. 1) is in line with lower glass gauge fitting. "C-C" should at no time be installed below crown sheet of boiler. Use 1" pipe for both steam and water equalizers. Provide valve below control for blowing out sludge periodically as shown in illustration No. 2.

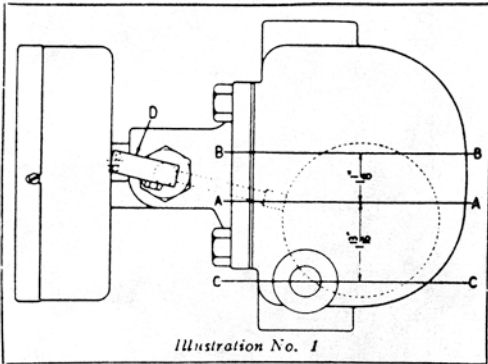

Illustration No. 1

CARE OF PACKING GLAND

All low water and pump feed controls require a reasonable amount of attention to insure dependable operation. The packing gland must be periodically tightened to prevent leakage. Should leaks occur, screw down on knurled packing gland nut until leak stops (use wrench if necessary). Next move operating arm up and down several times by hand and THEN BACK OFF NUT ONE-HALF TURN.

When repacking of the gland is required we recommend that standard packing be ordered from the factory.

To insure satisfactory operation at all times, this control should be checked daily. The engineer in charge should move the operating arm "D" up and down several times by hand, to insure free operation of the shaft. When boiler compounds are used, the float bowl should be blown out periodically.

CAUTION: When removing old or inserting new packing be careful not to gouge or score the operating shaft.

WIRING

Rigid conduit must not be attached to case. Use a short strip of BX to relieve control of conduit expansion and contraction strains. When fitting BX cable connector into case, be careful not to damage instrument mechanism.

The lead wires should be cut short and directly connected to the terminal posts.

Excessive lengths of wire crowded into the case interfere with the free movement of the mechanism and cause erratic operation.

Where control is directly connected into load circuit it must be connected in hot side of line. If in doubt as to which is the hot wire, connect one wire of a test lamp to a water pipe, or some other suitable ground. The lamp will light when the other wire (of test lamp) is connected to the hot wire.

Fuses installed in line switch should not exceed 10 amperes at 115 volts or 5 amperes at 230 volts.

ELECTRICAL RATING:

Furnished standard to withstand 10 amp. 115V, 5 amp. 230V. either A.C. or D.C. Motor rating, 1 H.P. Repulsion-Induction 1/2-H.P. Split Phase or D.C.

CAUTIONS — Note Carefully.

Keep cover closed and do not attempt to disconnect or change any parts. Do not overload. Note electrical rating on nameplate and be sure total current passing through switch is within this rating. Do not tamper with switch wires. Position of these wires is essential to proper operation. Tampering with these wires will void warranty.

CONTROL MOVEMENT MUST NOT BE OILED

NOTE:

Cold shock or water hammer must be avoided, as this condition may damage the float and prevent proper operation of the control.

ADJUSTMENTS

ADJUSTMENTS ARE FACTORY SET AND CANNOT BE CHANGED.

Type 123 opens circuit as liquid level lowers and is set to cut-out at level "A-A" and cut-in at level "B-B".

Type 123-3 opens circuit as liquid level rises and is set to cut-in at level "A-A" and cut-out at level "B-B".

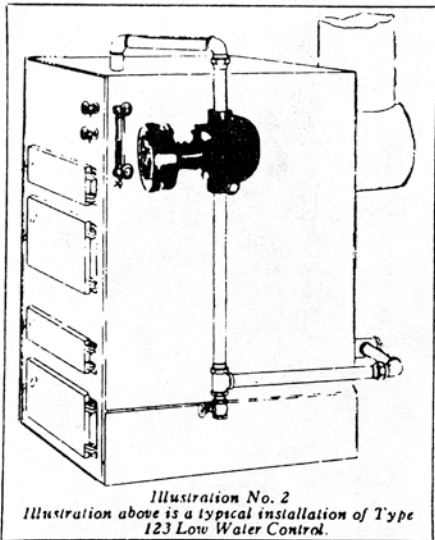
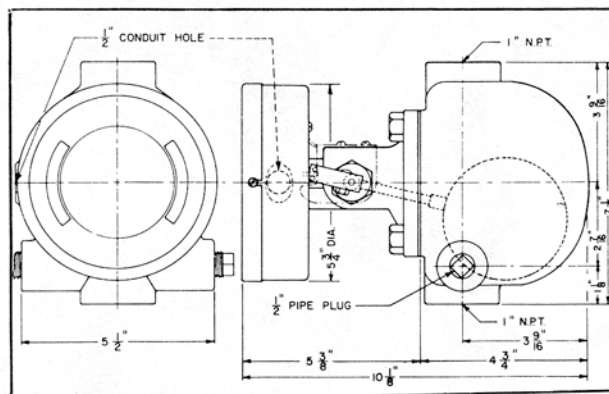

Illustration No. 2
Illustration above is a typical installation of Type 123 Low Water Control.

Not for use with lethal or flammable substances, either liquid or gaseous.



Distributed by:
M.A. Selmon Company, Inc
4 Oxford Rd.
Milford, CT 06460
203-377-3525



MERCOID DIVISION
DWYER INSTRUMENTS, INC.
P.O. BOX 258
MICHIGAN CITY, IN 46360 (USA)

PHONE 219 879-8000
FAX 219 872-9057
TELEX 25916