

INSTRUCTION MANUAL

HAWKLINK

- Remote Communications -



A higher level of performance



INTRODUCTION

PROPRIETARY NOTICE

The information contained in this publication is derived in part from proprietary and patent data. This information has been prepared for the express purpose of assisting operating and maintenance personnel in the efficient use of the instrument described herein. Publication of this information does not convey any rights to use or reproduce it, or to use for any purpose other than in connection with the installation, operation and maintenance of the equipment described herein.

WARNING

This instrument contains electronic components that are susceptible to damage by static electricity. Proper handling procedures must be observed during the removal, installation, or handling of internal circuit boards or devices:

Handling Procedure:

1. Power to unit must be removed prior to commencement of any work.
2. Personnel must be grounded, via wrist strap or other safe, suitable means, before any printed circuit board or other internal devices are installed, removed or adjusted.
3. Printed circuit boards must be transported in a conductive bag or other conductive container. Boards must not be removed from protective container until the immediate time of installation. Removed boards must be placed immediately in a protective container for transport, storage, or return to factory.

Comments:

This instrument is not unique in its content of ESD (electrostatic discharge) sensitive components. Most modern electronic designs contain components that utilize metal oxide technology (NMOS, CMOS, etc.). Experience has proven that even small amounts of static electricity can damage or destroy these devices. Damaged components, even though they appear to function properly, exhibit early failure.

CONTENTS

General Description	
Principle of Operation, Features	2
Glossary	3
QuickStart	4
Typical Applications	7
Dimensions	9
Parts	10
Mounting Instructions	11
Cable Type	12
Wiring	13
Facia Functionality Layout	15
Choosing your modem	
GSM or CDMA	16
Simcard Installation	17
Display Messages	18
Operating Instructions	
- GPRS	20
- CSD	24
- PC / Flashing HawkLink Firmware	27
Internal Software Flow Charts	
- Pushbuttons	28
- Software Tree	29
- Modem Setup (GPRS, CSD, PC Comms)	30
- Advanced Setup	31
- Diagnostic Displays	33
Troubleshooting	34
Specifications	36
Purchasing Part Numbers	37
Contact Information (back cover)	

GENERAL DESCRIPTION

The solution to remotely querying and customising Hawk units is the Hawk-Link. This is achieved by the Hawk-Link communicating through a mobile network to a GosHawk session running anywhere in the world. The HawkLink can be configured for both GSM (Quad-band) and CDMA networks, and in the near future the new 3G network.

The most significant feature of the HawkLink is to create a data connection between the user and the Hawk unit using the GPRS wireless communications protocol. This is currently only available using the GSM modem. CDMA modems use the traditional CSD data connection method.

HawkLink can perform MODBUS communications to Hawk units on a 234 wire network or to individual 2 wire Hawk units.

Important diagnostic information is displayed on the HawkLink LCD including network signal strength, network status and connection status.

PRINCIPLE OF OPERATION

HawkLink is designed to communicate in one of three modes:

- PC Comms mode; a PC running GosHawk.
- CSD Modem mode; CSD communication with a PC running GosHawk
- GPRS modem mode; GPRS communication through our local server to a local PC running GosHawk

During one of these communication modes, a GosHawk session can query or modify data in the HawkLink itself or to a specific addressed Hawk unit that is connected to the HawkLink.

FEATURES

- GSM/CDMA cellular network communications (3G to be added)
- CSD data connection (peer to peer)
- GPRS (TCP/IP) connection (via Hawk central server)
- Diagnostics of data communication and network status
- RS485 comms
- Accommodates 234 wire Hawk MODBUS network
- Accommodates 2 wire Hawk unit(s) (5 maximum)
- Remote 234 wire network reset option
- Remote control of HawkLink settings and operation

GLOSSARY

GSM

A type of cellular network that mobile devices connect to by searching for cells in the immediate vicinity.

This is a type of network implemented by many providers around the world. A GSM modem is available for the HawkLink unit.

CDMA

A type of cellular network that mobile devices connect to by searching for cells in the immediate vicinity. This is a type of network implemented by many providers around the world. A CDMA type modem is available for the HawkLink unit.

CSD - Cellular Switched Device

A protocol for wireless communications. In this case, between a HawkLink unit and GosHawk session.

GPRS/TCP - General Packet Radio Service/Transmission Control Protocol

A protocol for wireless communications. In this case, between a HawkLink unit and GosHawk session.

GosHawk

Control and querying software that in this application allows you to remotely access/query Hawk units that are connected to a wireless HawkLink unit.

HawkLink

The Hawk wireless communications unit. Attaches to a network of 234 Hawk units and up to five 2 wire Hawk units. A GosHawk session can connect to the HawkLink to query and/or modify data of attached units or the HawkLink itself

Modem

A wireless communication module inside the HawkLink unit. This allows you to perform wireless communications - similar to a cell phone.

Provider

The telecommunications company which produced your simcard and is also the company which will bill you for wireless services.

APN - Access Point Name

Used for a GPRS data connection. The APN determines what IP address is assigned to the modem, what security methods are used and how the GSM data network connects to the Internet.

Roaming

Ability for your simcard/provider to utilise other provider's cell towers for communication purposes.

PUK - Personal Unblocking Key

Used by mobile devices to unblock a locked simcard.

ESN - Electronic Serial Number

A unique serial number identifying a mobile device. Usually a CDMA device/modem. ESNs will eventually be replaced by MEIDs.

MEID - Mobile Equipment ID

MEID is a replacement for ESN. MEID is a different number representation for identifying a mobile device, usually a CDMA device/mode.

QUICKSTART

HawkLink Quickstart

1. Install Sim Card - See page 17.
2. Select a mounting location - See page 11.
3. Wire the HawkLink to power and wire Hawk units to HawkLink. See wiring diagrams on page 13.
4. Select the communication type (GPRS/CSD/PC).
5. See flow charts of the menu to select and setup each communication type.

GosHawk Quickstart

1. Install GosHawk (if required).
2. Start GosHawk and open the Properties window by selecting view -> Options.
3. Set up GosHawk for communication type. Refer to pages 20-27 for settings for each communication type (GPRS/CSD/PC).
4. Close Properties window and select Device ID. Select Device ID of the Hawk unit you wish to communicate with, or you can select the HawkLink itself (HL_ID).
5. Click Connect. Upon a successful connection the Info window will be displayed showing you data from the Device you're querying (Device ID).

Note: 'Waiting for connection' indicates waiting for connection with GosHawk.

The blinking green LED indicates unit has successfully connected.

QUICKSTART

GPRS COMMS

GPRS Modem Communications

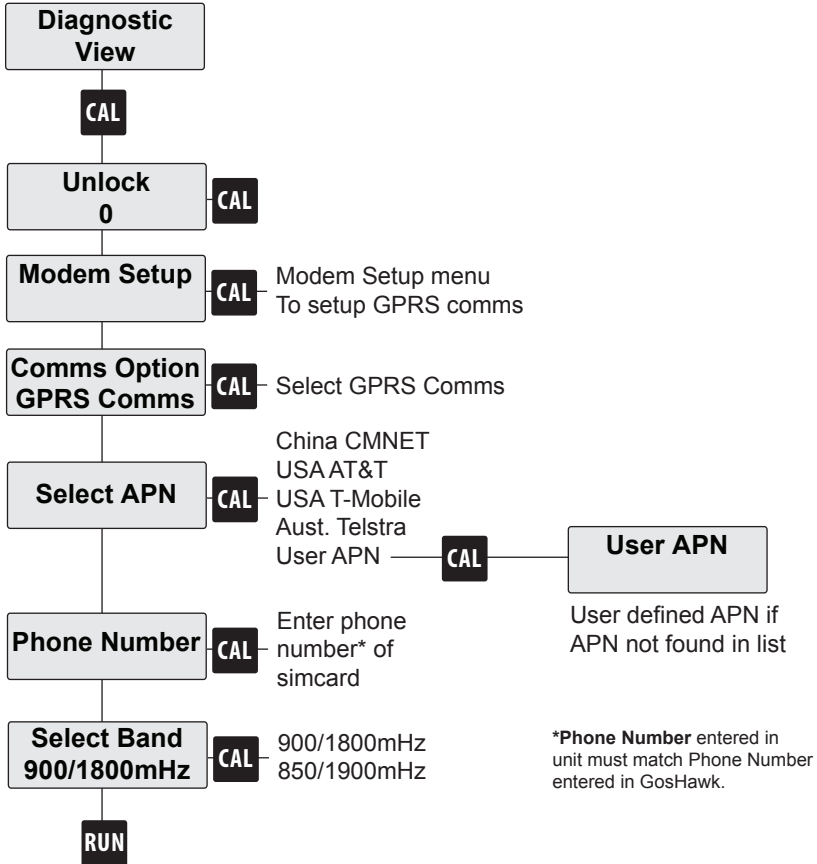

RUN

Press **RUN** twice at any time to resume or commence unit function

QUICKSTART

CSD Modem Communications

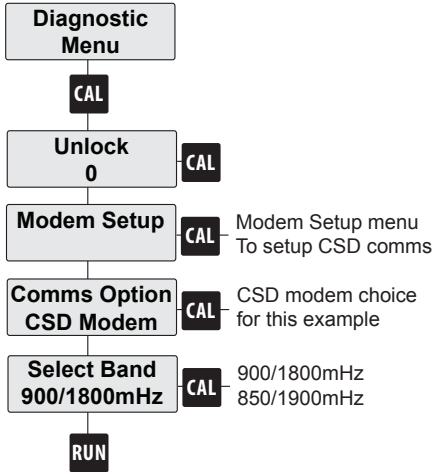

Press **RUN** twice at any time to resume or commence unit function

PC comms

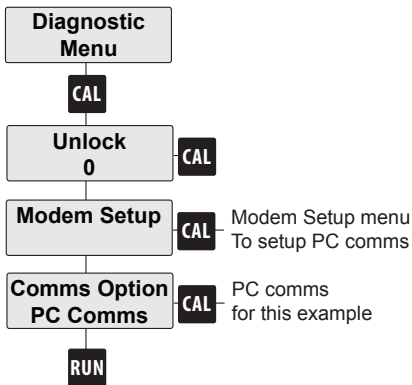

TYPICAL APPLICATIONS

HawkLink is Designed to create a MODBUS connection with a Hawk unit or network of Hawk units or a RS485 link to HawkLink. HawkLink is used when remote observation of a Hawk unit is desired.

Remote technical support and complete commissioning of equipment in applications is possible via the HawkLink module and allows continuous real time monitoring and adjustment of settings.

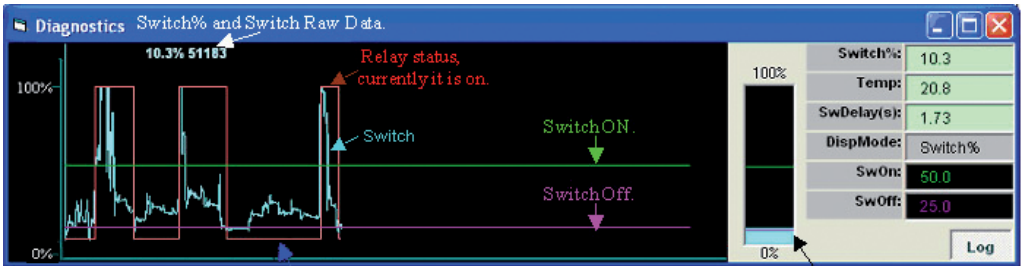

Relay status currently is off

Switch status bar

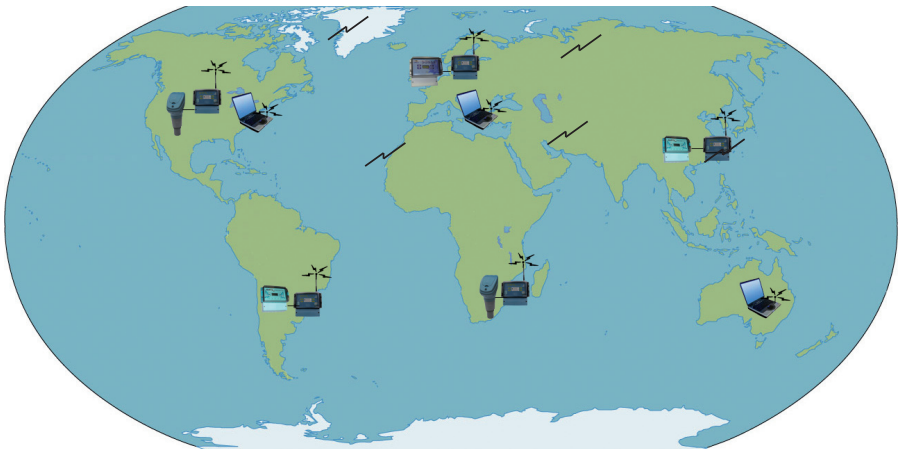

MULTIDROP CONNECTIONS

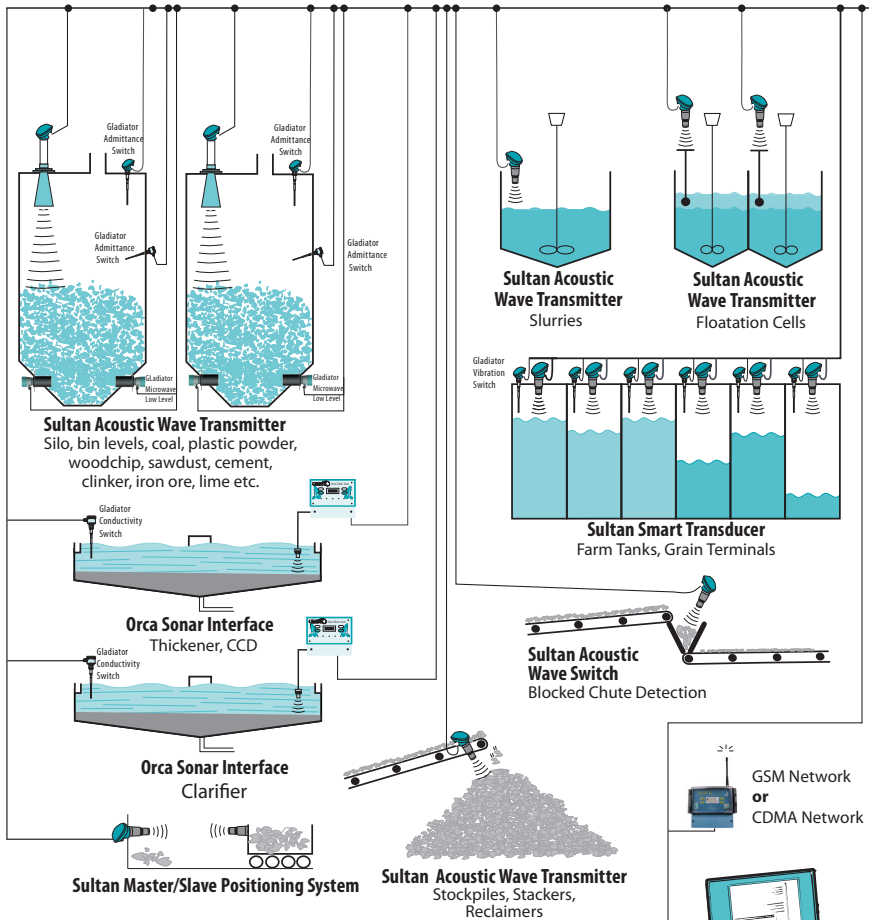

GSM or CDMA Network

- Typically up to 31 transmitters or switches per string.
- Maximum 250 transmitters or switches.
- Using GSM/CDMA network, transmitters and switches can be monitored, calibrated remotely.
- Alarm status, diagnostics can be monitored.
- Support from factory engineering for customer application problems.



Laptop or PC Communications
or PLC / DCS with
MODBUS RTU Port
GosHawk Software for
inventory monitoring on PC

(Limited Modbus query rate for Switches only)

DIMENSIONS

FRONT

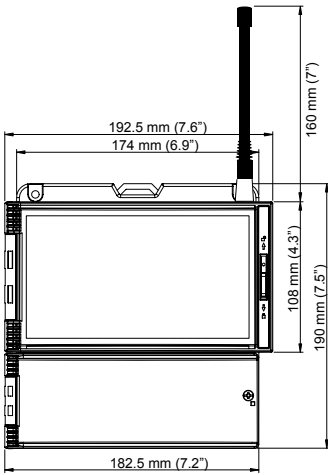

SIDE

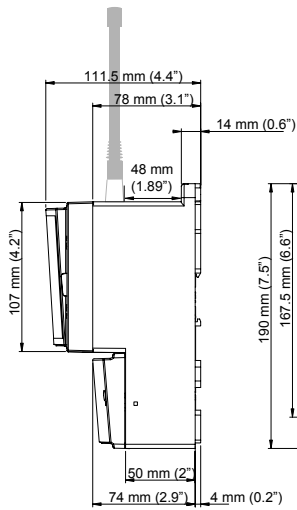

BACK

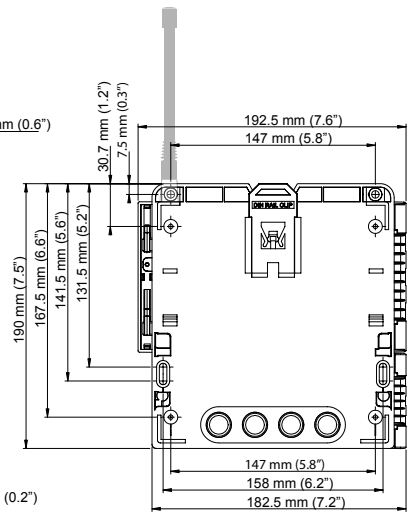

PARTS

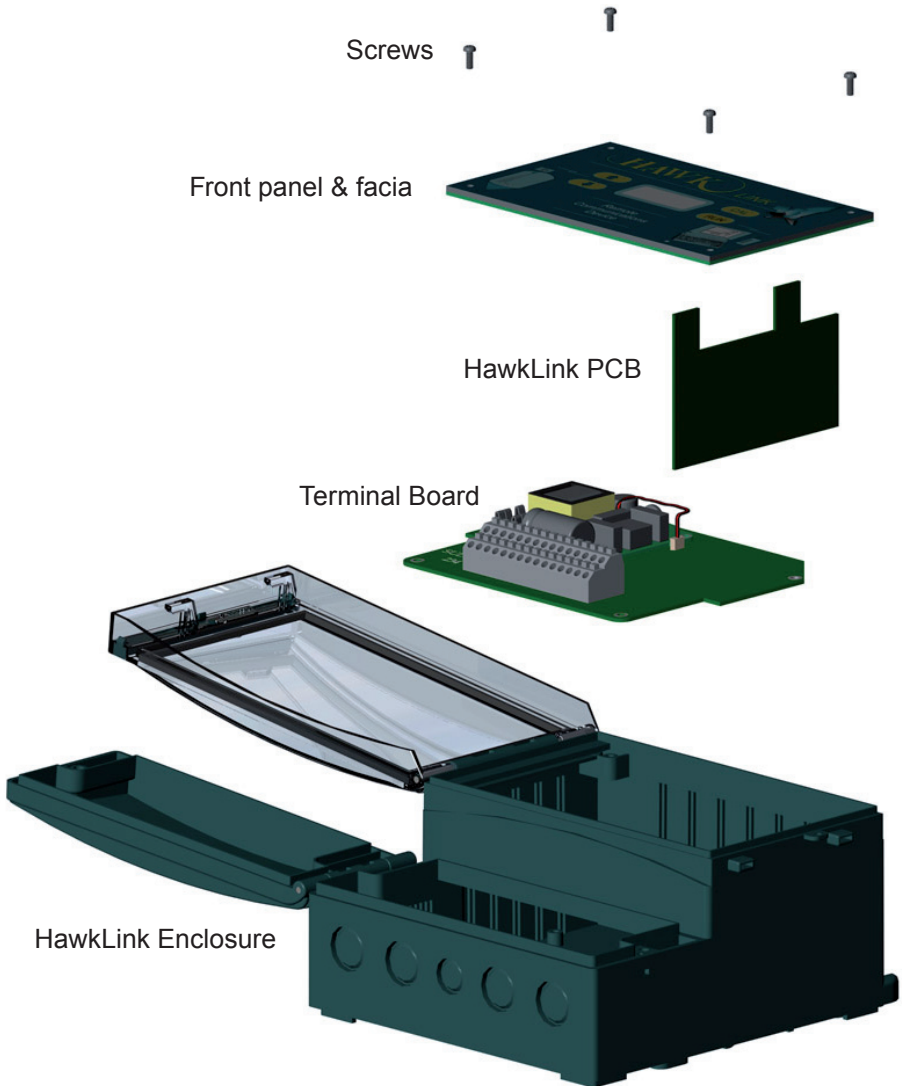

MOUNTING

Best signal quality may be available some distance from Hawk network. Run BELDEN 3084A combination cable.

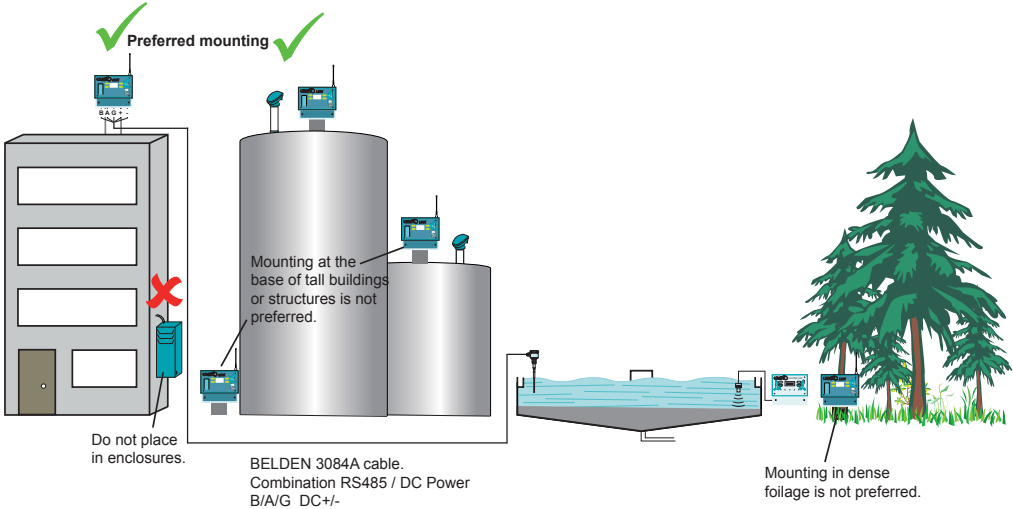

Signal Quality

At the place you wish to mount the Hawklink, check signal quality using the signal quality read-out on the Diagnostic screen of the HawkLink unit or put the simcard in a mobile phone and observe the signal quality bars on the mobile screen (note: it is possible there will be variation between a phone and the HawkLink due to difference in networks). You may need to mount the HawkLink some distance from your ideal location to achieve optimum signal quality. If this is the case you can extend the RS485 cable to a maximum of 500 meters.

The network provider's signal quality is

greatly affected by obstacles and surroundings.

Try to mount the HawkLink in the clearest location possible. Do not have it contained inside a metal enclosure. Try not to mount it at the base of buildings and large structures that could restrict the signal. If surrounding foliage is dense, this can have an adverse effect on signal quality. The worst case scenario may require replacement of the HawkLink antenna* or try a different modem type (GSM/ CDMA/3G).

Antenna

Make sure the antenna is not touching any objects. The antenna must never be bent.

*Standard antenna gain = 6db
If higher gain is used you will a Yagi type antenna (9,12,14db)

CABLE TYPE

Cable shorter than 500m (1640ft)

2 conductor shielded twisted pair instrument cable.

Conductor size dependent on cable length.

BELDEN 3106A (EIA Industrial RS-485 PLTC/CM).



Cable longer than 500m (1640ft)

When running cable over up to and over 500m away use the following cable to run RS485/MODBUS and DC power to the unit;

4 conductor shielded twisted pair instrument cable.

Conductor size dependent on cable length.

BELDEN 3084A

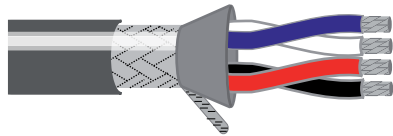

WIRING

CONNECTING COMMS

HAWKLINK MODEM TERMINAL BLOCK

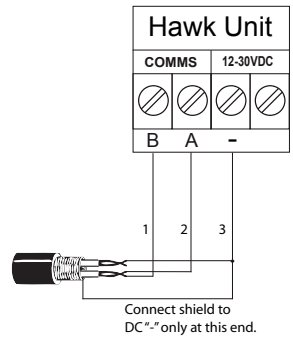
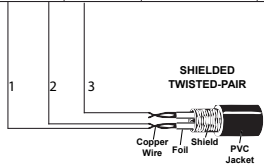
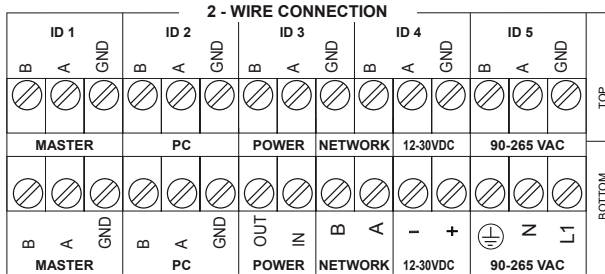

PLC CONNECTION

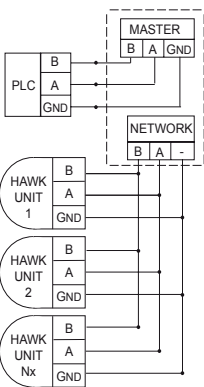

STANDARD CONNECTION

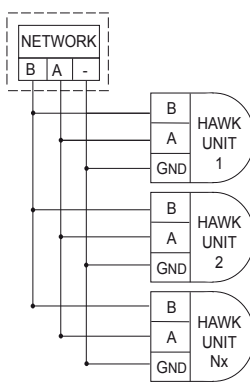

LOOP POWER CONNECTION

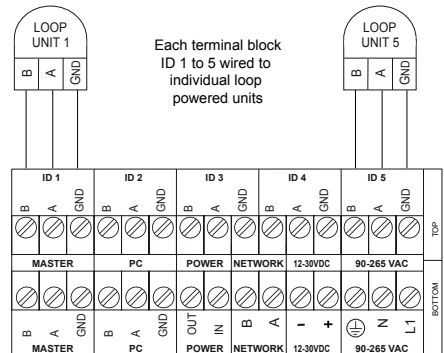

WIRING

MULTIDROP CONNECTIONS

Multidrop GSM/CDMA Connection*

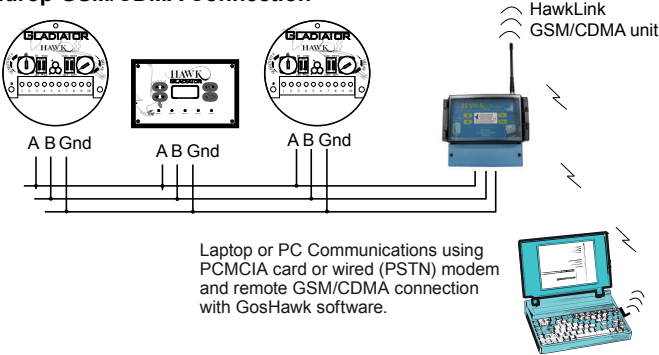

Multidrop Connection Using HawkLink USB*

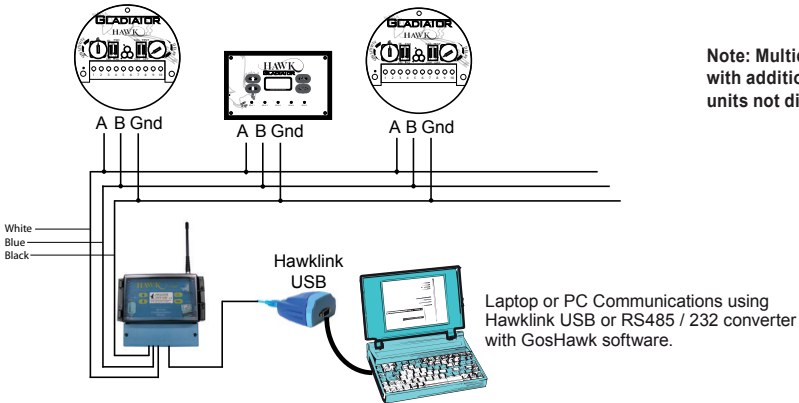

Multidrop Connection to PLC/DCS/SCADA*

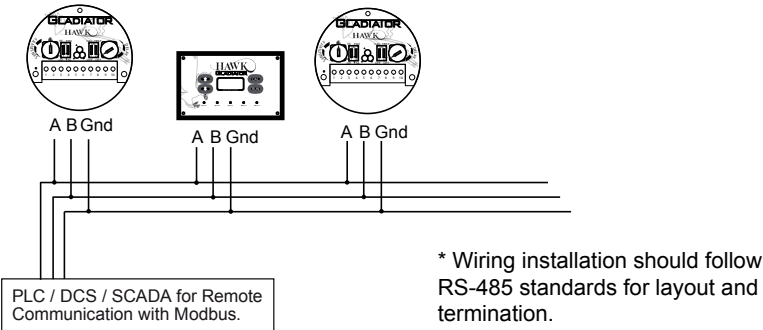

HAWKLINK FACIA LAYOUT

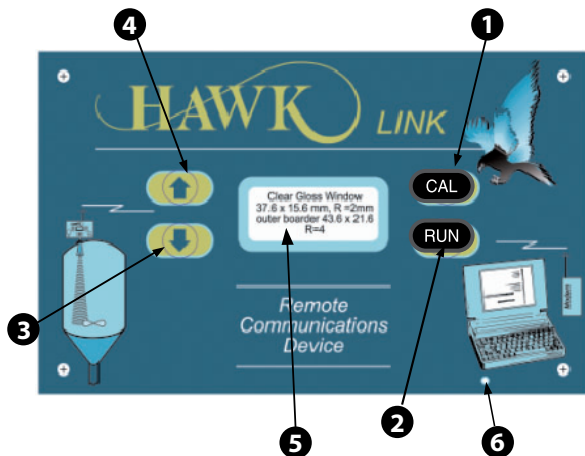

- 1 Calibrate button
- 2 Run button
- 3 Down button
- 4 Up button
- 5 Display (LCD with backlight)
- 6 Green Status LED

Solid light = Modem cannot register on a network or PIN needs to be entered.
1 second blink = Incoming call request
2 second blink = Registered on network

MODEM CHOICE

GSM or CDMA

There are currently two types of modem technologies that can be chosen for the HawkLink. Before choosing a modem find out the available cellular network technologies (GSM/CDMA) from providers in your application area and choose the one with adequate signal quality. A GSM modem is usually the preferred modem choice.

Signal Coverage Website

<http://gsmworld.com/roaming/gsminfo/index.shtml>

Useful for determining local signal coverage. Select your country and the provider. Select the coverage map. Determine the effective signal quality.

GSM Modem

Quad-band GSM/GPRS
900/800/850/900MHz. Ensure that your simcard is for GSM/GPRS and that the network supports the above frequencies. Ensure your simcard meets the requirements in the following Simcard Choice section.

CDMA Modem:

Currently CSD only with TCP functionality soon to be added. Most CDMA modems don't use a simcard (some countries use CDMA network simcards, you may need to consult local providers to find out what is available in your area). The modem is specially configured for your chosen provider. After factory configuration, the modem needs to be activated with the provider. They will need the ESN number of the modem which is normally written on a label found on the modem.

*For GSM modems Hawk recommends using a simcard with no PIN number.

SIMCARD CHOICE

This applies mostly to GSM type modems (CDMA modems in some countries also require simcards), Points to consider when sourcing a simcard:

- Know the provider of the simcard.
- For GPRS communications choose a suitable data/internet plan for the simcard. Ensure you enable GPRS communications.
- For CSD communications you must obtain a data number for the simcard.
- If using GPRS, know the APN of the provider of the simcard. The APN is the Access Point Name for GPRS connectivity with your chosen provider. APNs can have a username and password. This is not necessary and should be disabled when purchased. If assistance is required please contact factory.
- Know the simcard phone number. If simcard has a *PIN number, the HawkLink will detect at startup that one is required. It will use the default HawkLink PIN number (can be obtained from factory). If this is not the same number then the HawkLink will continue and show PIN Error on the Diagnostic screen. To enter the correct pin and at the same time change the default pin, follow the these steps:

To change PIN number:

1. Unlock 196
2. enter System Menu
3. press CAL to select Yes and change pin (max of 8 numbers, no spaces).
4. If the pin entered is correct then you can exit out to the Diagnostic screen.
5. If the pin is wrong Pin Error is displayed on the Diagnostic screen. The simcard remains inactive until the right pin is used.
6. Upon 3 unsuccessful pin entering attempts, the PUK code is required and can only be accessed upon reset and startup of the HawkLink. Upon entering the PUK code you are then asked for a new PIN number.

SIMCARD INSTALLATION

Follow the steps below to install a simcard.

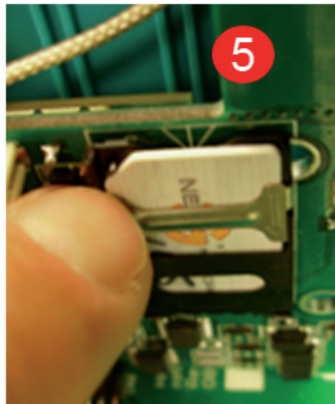
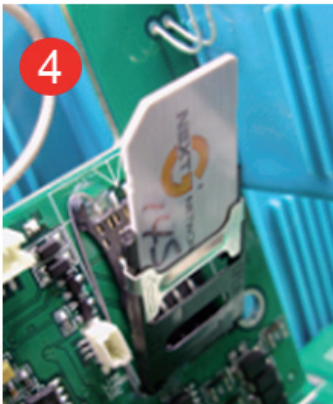
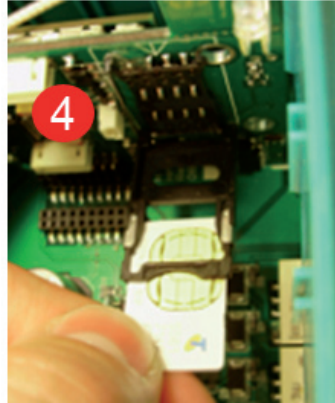

1. Ensure the power cable is unplugged.
2. Remove the Facia and locate the sim card holder – do not unplug or remove the HawkLink board from the enclosure.
3. Unlock the hinged holder by lightly sliding the metal latch in a downwards direction releasing the hinged card holder.

4. Slide the simcard into the holder with the simcards electronic side facing upward as indicated.
5. Push the card holder back into its original position and re-lock the sliding hinge.

DISPLAYED MESSAGES

Startup

When power is applied to the unit startup messages are immediately displayed on the LCD. The following messages are part of the start up phase of HawkLink.

Serial Number – Serial number of the HawkLink unit.

Type – Hawk unit type.

Software Version – Version of HawkLink software.

MB Address – Modbus address of unit.

Modem Okay – Tests for the presence of the embedded modem.

Diagnostic Screen - The Diagnostic screen is the top most part of the menu. It has 2 sub menus as seen in the menu flow diagram for the Diagnostic menu on **page 33**. The top most Diagnostic screen is used to indicate the comm type chosen on the top line and the status of connection/errors/communication messages on the second line.

Simcard Messages

NetReg: Fail – This can occur for many reasons. Ensure the HawkLink is mounted in a position and location that is ideal for good signal strength (see the mounting section on page 11). Make sure the simcard is activated and operational with its provider.

No Sim Card! – No simcard detected.

Sim Error – The simcard is faulty or the PUK has been entered incorrectly more than 0 times rendering the card useless.

Pin Error – Displayed if the PIN number used by the HawkLink is not the same as the pin number for the simcard. Use the System menu to change the PIN number used by the HawkLink. It will automatically attempt to use this PIN number once entered. (Unlock 96 -> System Menu -> Pin Number). The other option is to disable the PIN number option on the simcard using a mobile phone.

Wrong PUK – The PUK entered is wrong.

Diagnostics Messages

Waiting for Connection – This HawkLink is waiting for an incoming connection request. It is in an idle state.

GosHawk Connected – Displayed to indicate completed connection.

Transmitting – Displayed for a successful query of an attached Hawk unit. The result from the query is immediately sent out to the modem and ultimately back to the GosHawk session.

Receive Only – Displayed when a Modbus query is received by the HawkLink but fails to receive a reply from the addressed Hawk unit.

DISPLAYED MESSAGES

Remote Connection

During remote connection attempt by the HawkLink to the Hawk Server there are a series of messages displayed. Each message can be accompanied by either Pass or Fail.

Run IP Stack – The IP stack within the modem is executed.

TCP Delay

GPRS Running? – Check if GPRS is already running. If it is then routine skips.

Open GPRS – Open the GPRS bearer.

Set APN – Define the APN address of provider's GPRS server.

Start GPRS – Start a GPRS connection.

HawkLink Con – Connect to Hawk Server.

TCP DataMode – Establish transparent data connection.

Pwd/ID Chk – Send defined password and ID (simcard phone number) to the server for verification.

Pwd/ID Chk OK – Displayed if password and ID are correct.

Failed to Connect – Displayed if any of the above messages are accompanied by a fail message.

OPERATING INSTRUCTIONS

GPRS

Ensure the HawkLink unit is set to GPRS Modem. You can confirm this by checking the Diagnostic screen. It should say GPRS Modem Waiting for Connection. If the HawkLink is not set in this way, change the comms choice to GPRS Modem within the Modem Setup Menu. Refer to the flow chart on page 5 for GPRS Modem communications for setup assistance.

GosHawk Settings

Click on View->Options. Fill out the fields similar to what you see below. Ensure that you choose Type: HawkLink Server as this will cause GosHawk to connect to the Hawk Server and request a prompt the HawkLink to connect to the Hawk Server.

The screenshot shows a 'Properties' dialog box with several sections:

- Filter Settings:**
 - Client: HAWK MEASUREMENT SYSTEMS
 - Site: DEMO
 - ID: 01
- Comms Settings:**
 - Type: HawkLink Serv
 - ModemNo: 0448525687
 - Port: Dial from Serve
 - Password: 16
 - Freq: 0.5 Sec
 - DialNo: 001161448525687
 - TimeOut: 5.00 mS
 - Socket: 1
 - Speed: 19200
 - ConTimeOut: 60
- Display Settings:**
 - Units: Metres
 - Vol Units: Cube mtr
 - Time Units: Second
 - Total Units: Cube mtr
- Access Level:**
 - Password: *****
 - Access Level: Engineering
- Network Tank View Settings:**
 - Network Tank View button
 - Network Tank View Disabled! (in red text)

At the bottom, there is a note: "Add Device ID or Select Device ID From the list:
- Double click to update selected ID.
- Enter new ID, then press Enter key to add new ID."

OPERATING INSTRUCTIONS

GPRS

Comms Settings

Type: The communication type that GosHawk is to execute

Port: The connection type for communication ie. COM1, COM3, Dial from Server.

This defines what physical hardware is used to dial and prompt the HawkLink modem. The DialNo field is used by this hardware. For example; if the internal modem of your PC is using COM3, then the modem will use the number entered in DialNo.

Freq: Time between sending queries.

Timeout: Delay for expecting query response. This will vary at times. The minimum recommended timeout value is 400ms.

Speed: Not applicable for this configuration.

ModemNo: ID of the HawkLink you want to connect to. This is identical to the sim-card number. This same number needs to be entered into the HawkLink.

Password: Password, ensure the same password is entered into HawkLink

DialNo: Used to wake up the HawkLink modem. It is the phone number of the modem within the HawkLink. As mentioned, DialNo is used by the hardware choice in the Port field. It is important to know that you may require a prefix to the phone number. The following are scenarios where this may be necessary:

Dialing from Server (located in Australia)

HawkLink located in Australia

No prefix numbers required

HawkLink located in another country from where you are

00 + country code of HawkLink location

HawkLink located in the same country as you

00 + country code of HawkLink location

Dialling from Modem (connected to your PC - internal/external)

You may also dial from mobile or fixed line.

HawkLink located in another country from where you are

Your country's international dialling prefix
+ country code of HawkLink location

HawkLink located in the same country as you

No prefix

Socket: The socket number of the server

ConTimeOut: the timeout for established communication between GosHawk and HawkLink

OPERATING INSTRUCTIONS

GPRS

Connection Sequence

Click Connect

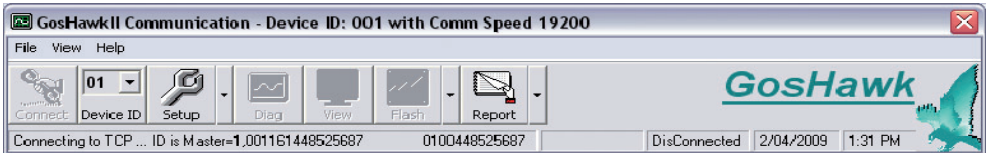

Hawk Server dials HawkLink

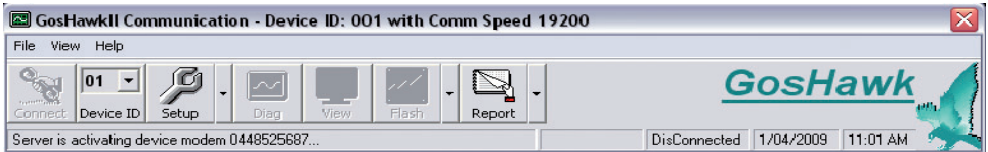

GosHawk waits for HawkLink connection confirmation from server



Password and ID verification process

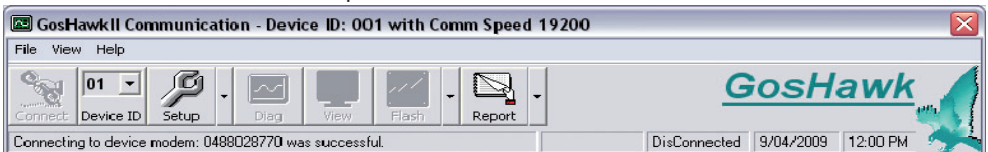

Password and ID verification passed



GosHawk sends query to HawkLink

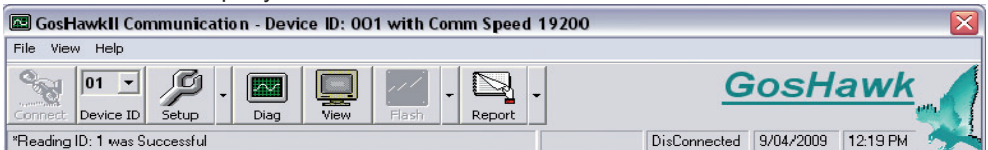

OPERATING INSTRUCTIONS

GPRS

Successful response from HawkLink



GosHawk has a connection through the server to the HawkLink unit

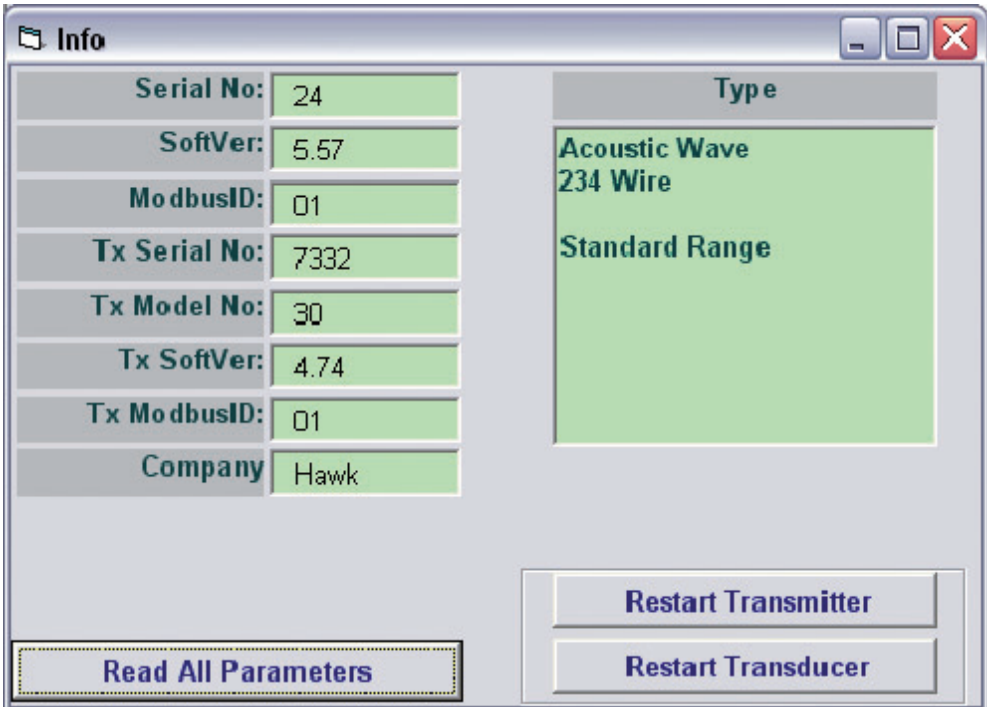

OPERATING INSTRUCTIONS

CSD

Make sure the HawkLink is set to CSD Modem. You can confirm this by checking the Diagnostic screen. It should say CSD Modem Waiting for Connection. If the HawkLink is not set in this way, change the comms choice to CSD Modem within the Modem Setup Menu. Refer to the flow chart on page 6 for CSD Modem communications for assistance.

Note: CSD communications requires a data number to be allocated to the simcard. This is obtained from the network provider of the simcard. **It will not work with a voice number.**

GosHawk Settings

Click on View->Options. Fill out the fields similar to what you see below. Ensure that you choose Type: Modem as this will cause GosHawk to use the internal PC modem to dial the HawkLink modem, ultimately forming a connection.

The screenshot shows a 'Properties' dialog box with several sections:

- Filter Settings:** Client: HAWK MEASUREMENT SYSTEMS, Site: DEMO, ID: 01.
- Comms Settings:** Type: Modem, Port: Com3, Freq: 0.5 Sec, TimeOut: 500 mS, Speed: 19200. DialNo: 001161448525687.
- Modem:** Setup Time(s): 10, Modem Initialisation: .
- Display Settings:** Units: Metres, Vol Units: Cube mtr, Time Units: Second, Total Units: Cube mtr.
- Access Level:** Password: [masked], Access Level: Engineering.
- Network Tank View Settings:** Network Tank View button, Network Tank View Disabled! (in red).

Enter CSD modem number.

OPERATING INSTRUCTIONS

CSD (con't)

Comms Settings:

Type: Type of comms. In this case comms through the PC's modem.

Port: Com port where the modem is located.

Freq: Time between sending queries.

Timeout: Delay for expecting query response.

Speed: This is the speed at which communications takes place. 115200 is the max speed.

DialNo: Used to connect to the HawkLink modem. It is the phone number of the modem within the HawkLink. As mentioned, DialNo is used by the hardware choice in the Port field. It is important to know that you may require a prefix to the phone number. The following are scenarios where this may be necessary:

HawkLink located in another country from where you are

Your country's international dialling prefix
+ country code of HawkLink location

HawkLink located in the same country as you

No prefix

Connection Sequence

Click Connect



Dial Number prompt should appear, click OK

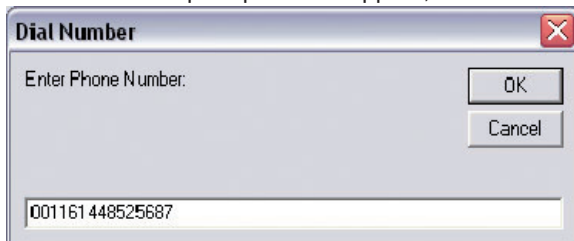

Dialing progress bar will appear



OPERATING INSTRUCTIONS

CSD (con't)

GosHawk setting up connection with modem



GosHawk sends query to HawkLink



Successful response from HawkLink



GosHawk has a connection through the Hawk server to the HawkLink unit



OPERATING INSTRUCTIONS

PC Comms / Flashing HawkLink Firmware

Linking between Hawklink and PC/Laptop

You will need to connect RS485/USB converter from the HawkLink unit to your PC/ Laptop. The A/B/GND lines connect to the PC A/B/GND terminal block connections on the HawkLink terminal board. Make sure you know the USB Comm port number you are connecting to on your PC/Laptop



Configure the HawkLink for PC communications GosHawk Settings

Open GosHawk on your PC/Laptop, select menu View -> Options.

Below is an example of settings required for communications to the HawkLink unit.

NOTE: 19200 Baud Rate required for flashing! Also, Device ID must equal HL_ID to communicate with the HawkLink directly.

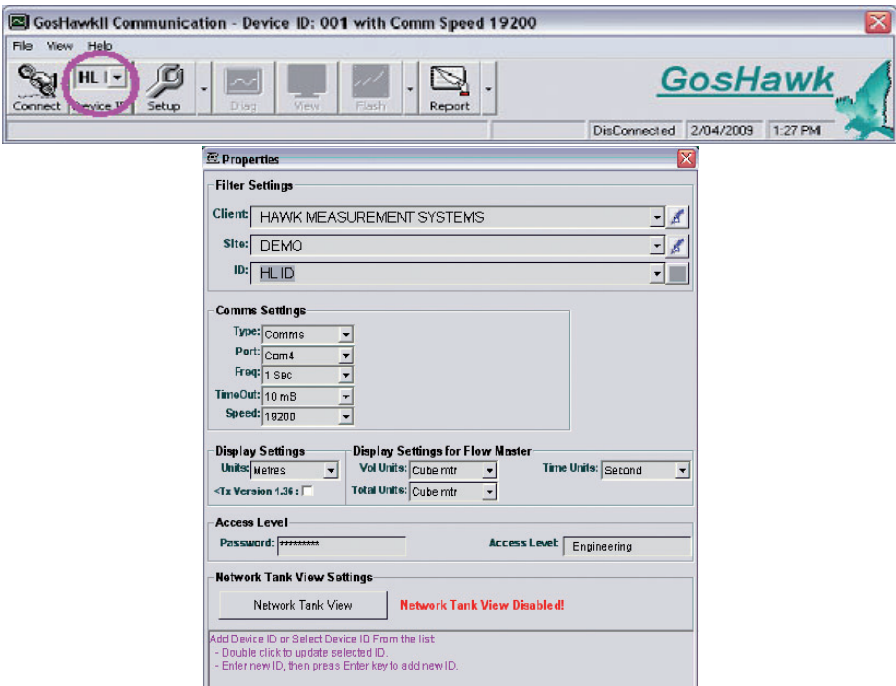

SOFTWARE MENU

REMOTE AMPLIFIER

ENTERING DATA

All software adjustments are achieved via the four PUSHBUTTONS on the front panel.



In Run Mode

- (A) Press and hold - interrupts normal operations and allows access to software menu headings.

In Calibrate Mode

- (B) Steps into a menu selection to allow editing (down one level)
- (C) Saves selected value and moves onto the next menu item.



In Run Mode

- (A) Scrolls up through operating diagnostics on display LCD.

In Calibrate Mode

- (B) Scrolls up through software parameters when browsing the menus.
- (C) Increases display value when editing a parameter.



In Run Mode

- (A) Scrolls down through operating diagnostics on LCD display.

In Calibrate Mode

- (B) Scrolls down through software parameters when browsing the menus.
- (C) Decreases display value when editing a parameter.



In Run Mode

- (A) Hides diagnostics if they are in view and returns to the standard running display.

In Calibrate Mode

- (B) Steps out of a menu or selection (up one level). Parameter value will be stored automatically when stepping up.
- (C) Returns to running mode from the top level menu.

FLOW CHART SOFTWARE TREE

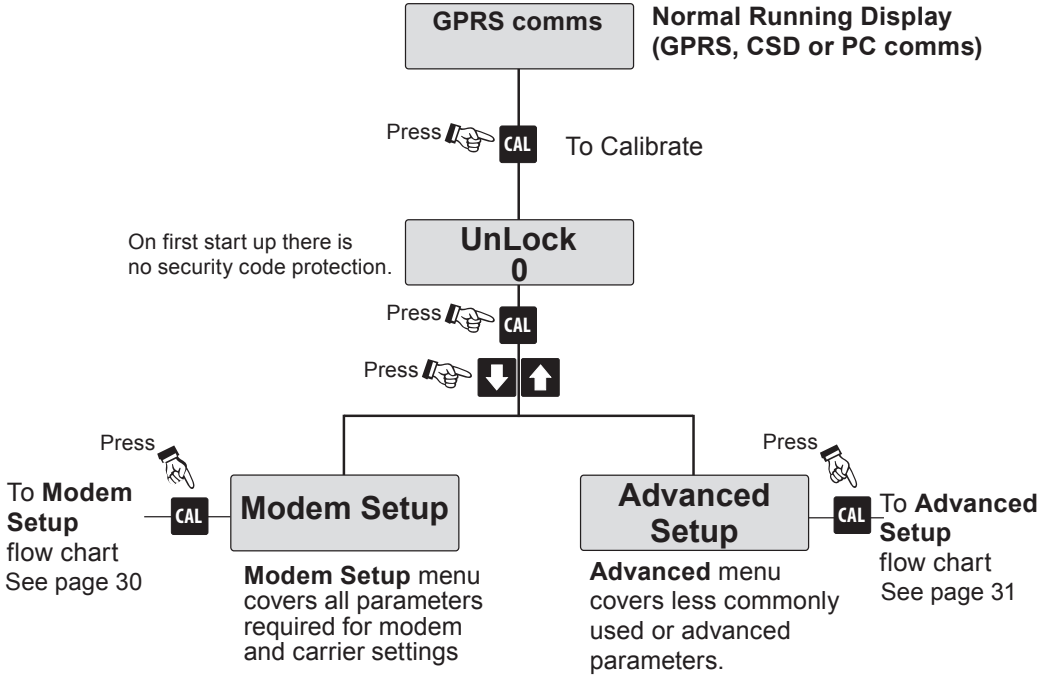

Press **RUN** twice to return to normal operation

FLOW CHART

MODEM SETUP

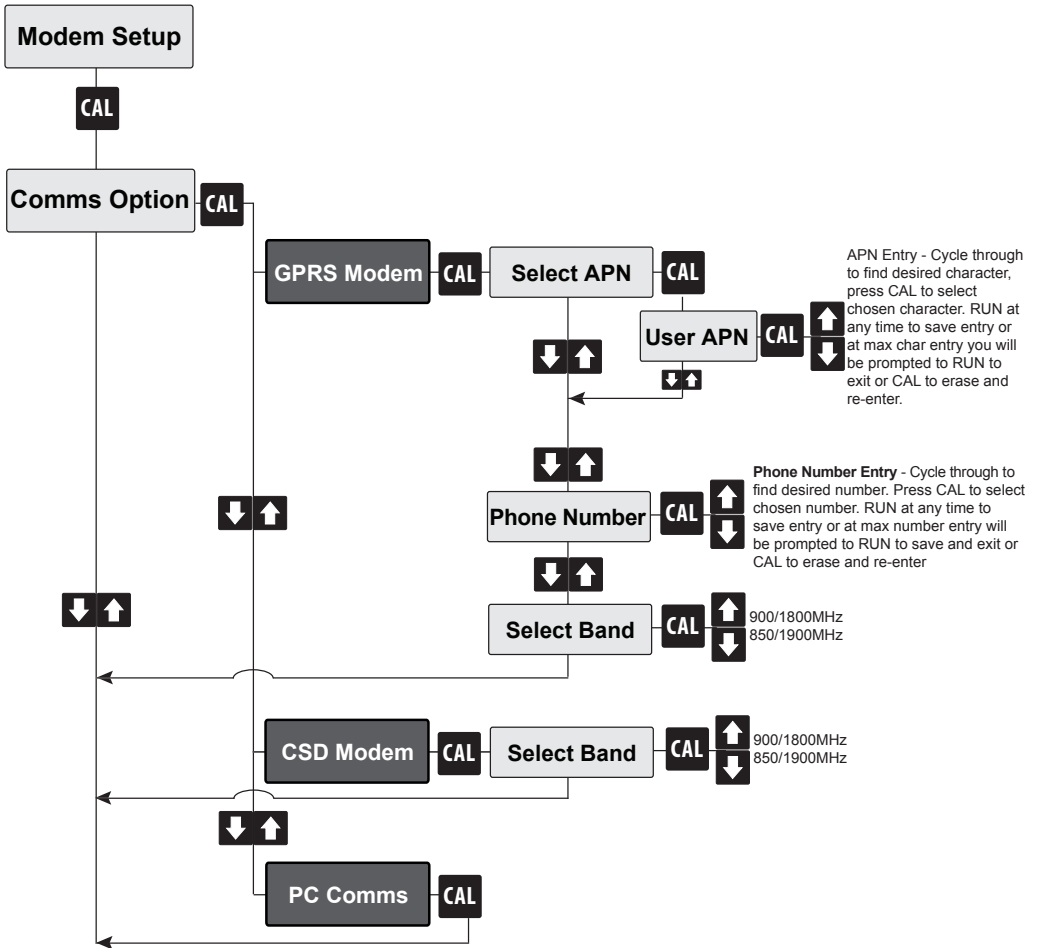

FLOW CHART

ADVANCED MENU

Note: It is preferred Advanced Settings are altered only under instruction.

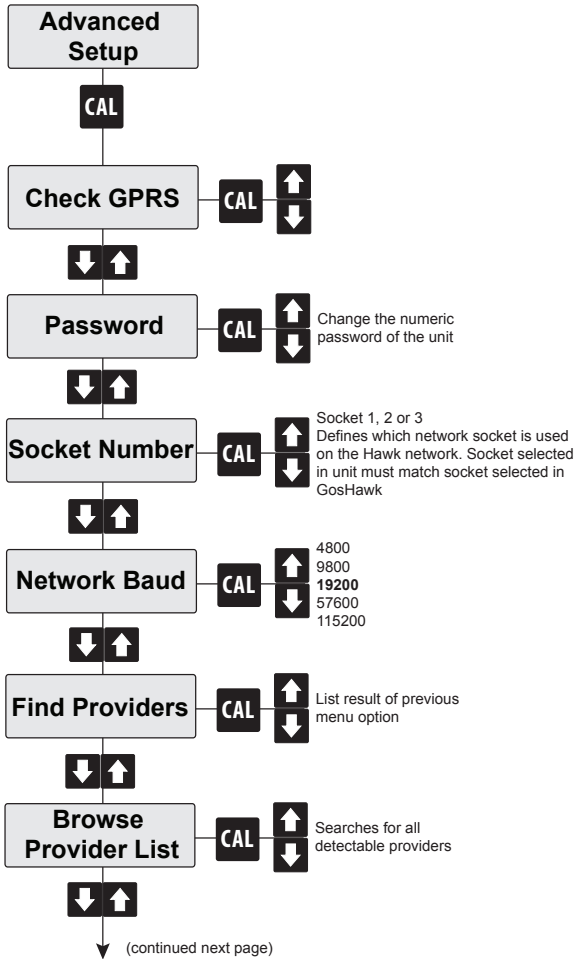

FLOW CHART

ADVANCED MENU

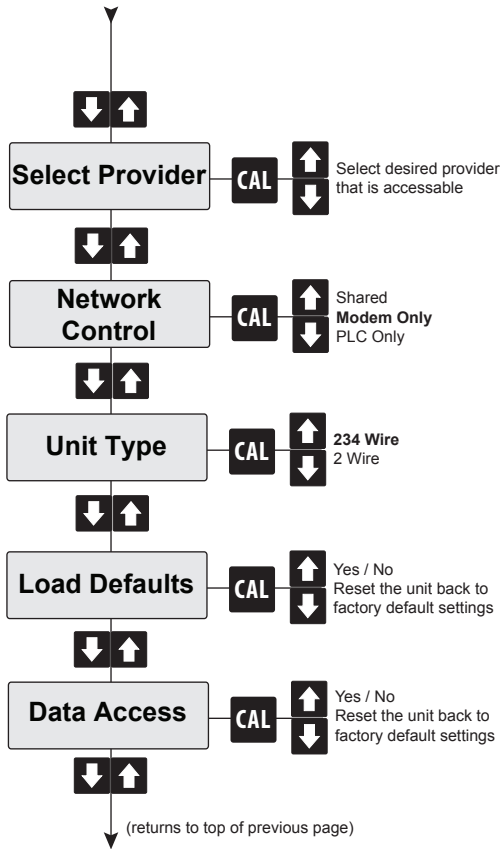

FLOW CHART

DIAGNOSTIC DISPLAYS

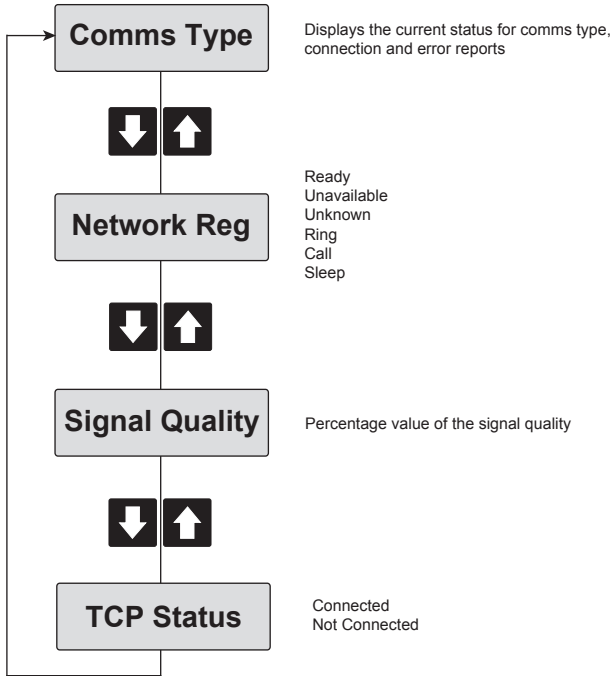

TROUBLESHOOTING

Issue	Resolution
<p>During CSD or GPRS HawkLink - Gos-Hawk connection, Diagnostic screen shows Receive Only during MODBUS communications.</p>	<ul style="list-style-type: none"> • The Diagnostic should show Transmitting. This issue means that the MODBUS query is not being issued a response from the Hawk unit attached to the HawkLink unit. Check the wiring between the units.
<p>Solid LED during GPRS or CSD comms</p>	<ul style="list-style-type: none"> • Make sure a simcard is inserted into the HawkLink. • The pin number used by the HawkLink may be wrong. Use Unlock 196 -> System Menu -> PIN Number to change the pin number used by the HawkLink, or put the simcard in a mobile phone and deactivate the PIN number function. • The band setting of the modem could be wrong. Check HawkLink menu flowchart to see how to change the band.
<p>NetReg: Fail</p>	<ul style="list-style-type: none"> • Bad signal quality; move to a better location. • Wrong modem band setting. Check HawkLink menu flowchart to see how to change the band.
<p>No Sim Card!</p>	<p>Modem cannot detect the presence of a simcard; Ensure one is inserted.</p>
<p>Sim Error</p>	<ul style="list-style-type: none"> • Simcard could be invalid or faulty • Simcard may not inserted properly • Simcard may not be present

TROUBLESHOOTING

PIN Error	<ul style="list-style-type: none">• The pin number used by the HawkLink may be wrong. Use Unlock 196 -> System Menu -> PIN Number to change the pin number used by the HawkLink, or put the simcard in a mobile phone and deactivate the PIN number function.
Wrong PUK	<ul style="list-style-type: none">• If 3 failed PIN entering attempts have occurred, a PUK code is required, if the PUK code entered is incorrect than this is displayed; obtain correct PUK (10 failed PUK attempts renders simcard permanently inactive).
Failed to Connect	<ul style="list-style-type: none">• Briefly displayed at the end of a GPRS/TCP connection attempt; can occur for the following reasons; APN incorrect, password incorrect, ID incorrect

SPECIFICATIONS

Operating Voltage

- 7 - 30Vdc (residual ripple no greater than 100mV)
- 80 - 260Vac 50/60Hz

Power Consumption

- <0.8W @ 24Vdc
- <5VA @ 240Vac
- <3VA @ 115Vac

Communications

- Modbus/RS485
- GSM/CDMA/3G
- Multidrop mode can address 1-250 units over 4 wires

Operating Temperature

- -40°C (-40°F) to 80°C (176°F)

Max cable (non wireless) PC / HawkLink separation

- Up to 500m (1640ft) BELDEN 3106A (EIA Industrial RS-485 PLTC/CM).
- Over 500m BELDEN 3084A

Maximum Operating Pressure

- 2 BAR (absolute)

Display

- 2 line x 12 character alphanumeric LCD
- Backlight standard

Enclosure Sealing

- IP65 (Nema 4x)

Cable Entries

- 4 x 20mm (0.8"), 1 x 16mm (0.6") knock outs

PART NUMBERING

SMART PROBE VERSION

Model
HL HawkLink

Type

R Remote stand alone system c/w antenna

Power Supply

B 24VDC

U Universal 90-260VAC

X No power supply for E selection

Network Type

G2 GSM Frequency 850/1900 MHz/19200 Baud for USA, Canada, Argentina, Chile for Sultan / ORCA

G4 GSM Frequency 900/1800 MHz/19200 Baud for Australia, Europe, Brazil for Sultan/ ORCA Sonar,

G6 GPRS/TCP and CSD compatible, Quadband capability, GSM frequency 850, 900/1800, 1900MHz

P Phone Line

E Ethernet

Simcard

S3 Australian Simcard expires after 3 month

S12 Australian Simcard expires after 12 month

HL	R	B	G4	S3
----	---	---	----	----

Contacts

Hawk Measurement Systems (Head Office)

15-17 Maurice Court

Nunawading VIC 3131

Australia

Phone: +61 3 9873 4750

Fax: +61 3 9873 4538

info@hawk.com.au

Hawk Measurement

7 River Street

Middleton, MA 01949

USA

Phone: +1 888 HAWKLEVEL (1-888-429-5538)

Phone: +1 978 304 3000

Fax: +1 978 304 1462

info@hawkmeasure.com

For more information and global
representatives:

www.hawkmeasure.com

Represented by:

