

A Higher Level of Performance



Data Sheet

Sultan

Acoustic Wave Series

Machinery Positioning Systems



For more information, please visit >
www.hawkmeasure.com



Principle of Operation

The Sultan for Machinery Positioning systems consists of two systems. One is a standard Sultan programmed to 'Position' mode, the other is a special Sultan Slave system (software option PS). One system is generally mounted on moving machinery and the other at a fixed location.

The 'Master' pulses are detected by a 'Slave' transducer which immediately emits a pulse back to the Master. The Master transmitter calculates transit times and provides an output proportional to the position of the moving machinery in relation to the Slaves fixed position. There is NO wiring requirement between the 'Master' and 'Slave' transducers, which allows for easy retrofit to existing shuttle conveyors, cranes, stackers, reclaimers, etc.

Dust, background noise, wet atmosphere, high winds can be compensated for by proper selection of operating frequency of the transducer e.g. use lower frequency transducers where high dust, high wind conditions prevail.

Function

The Sultan series includes a product range specifically designed for machine position sensing. Such a system is typically used to provide a signal representing the linear position of a moving machine to a control system.

Certifications

IECEX, ATEX, CSA.

Primary Areas of Application

- Shuttle conveyor collision protection & positioning
- Stacker/reclaimer collision protection & positioning
- Transfer conveyor collision protection & positioning
- Crane / Shploader collision protection & positioning
- Dirty / dusty / build up prone applications.
- Self Cleaning sensor face requires no maintenance.

Features

- Non contact measurement
- Range to 195m (640ft)
- Wide range of communications:
DeviceNet, GosHawk, HART, Modbus, Profibus DP, Foundation Fieldbus & Profibus PA
- Auto compensation for dust, steam and losses
- Protection class IP67, NEMA 4x (IP68 Transducer)
- Programmable fail safe mode
- 3G remote setup options / configuration

Typical Applications

Sultan Acoustic Wave Series



Shuttle Conveyors

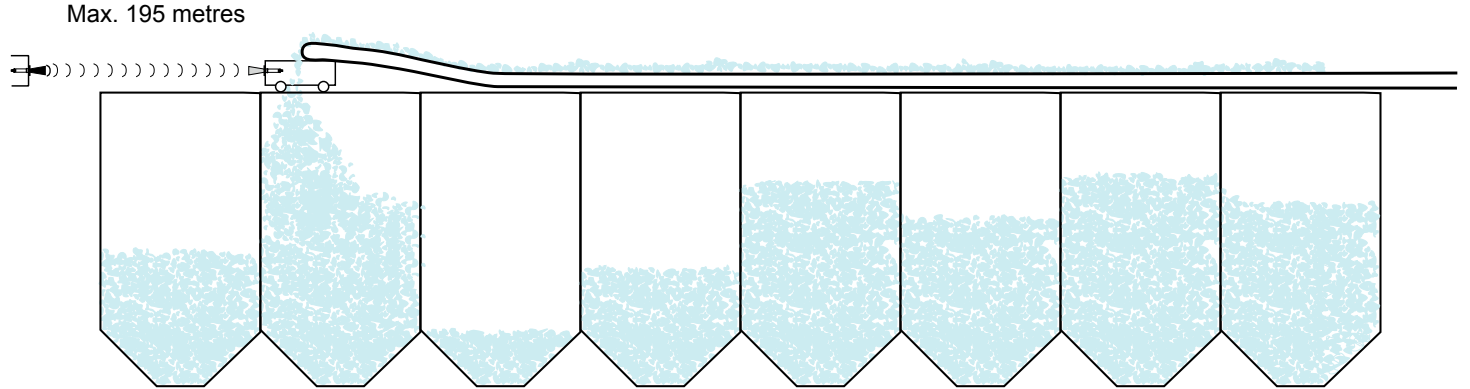

Bunker Discharge Wagons

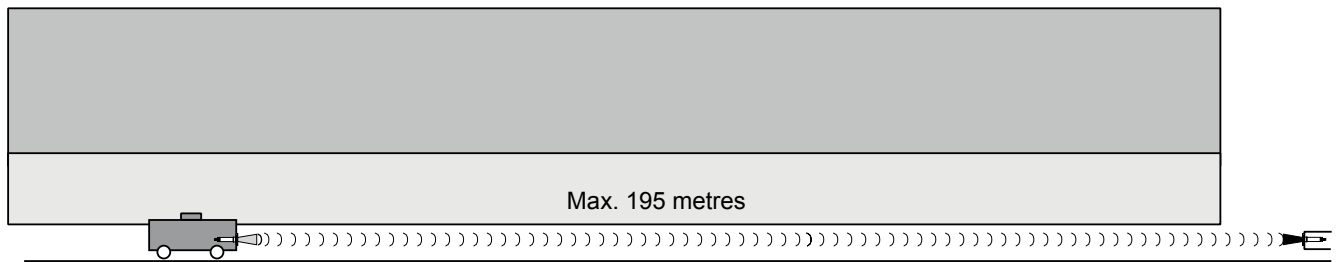

Stacker / Reclaimers

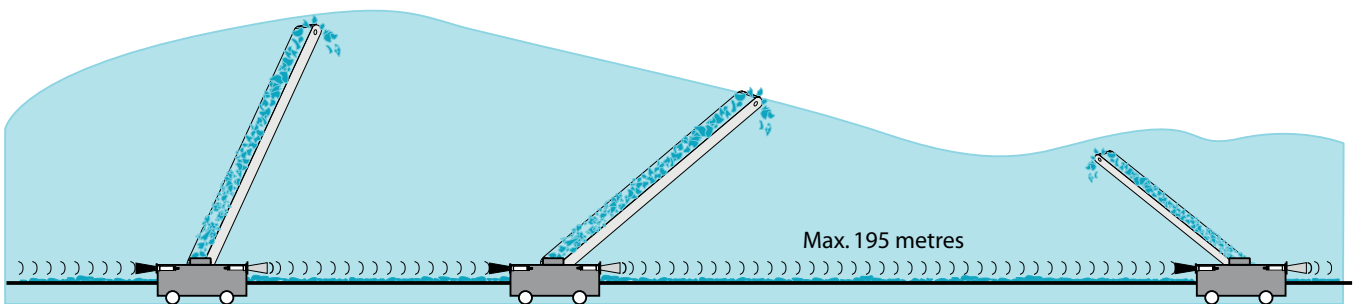

Typical Applications

Sultan Acoustic Wave Series



Dimensions

Sultan Acoustic Wave Series



Integral Units

Standard Type

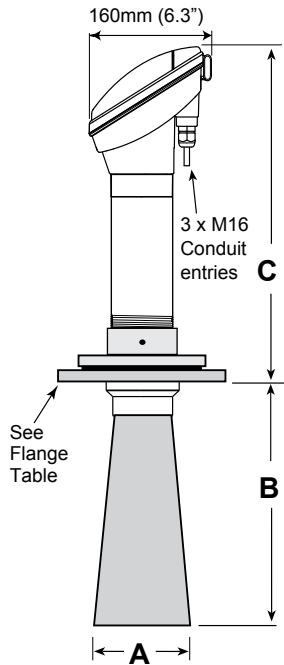

Compact Type (2" BSP / NPT)

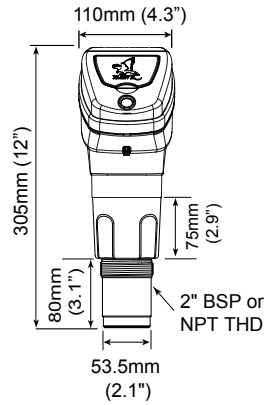

Remote Transducers

Standard Type

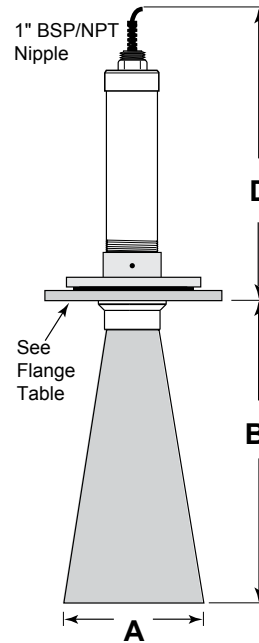

Compact Type (2" BSP / NPT)

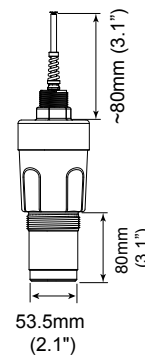

All cones must protrude into the main volume of the vessel by at least 50 mm (2 inches) past the lower end of the mounting nozzle.

Cone / Transducer Dimensions Table

Sensor Frequency	Selected Flange	A		B		C		D	
		mm	in.	mm	in.	mm	in.	mm	in.
5 kHz	10"	236	10.0	455	17.9	840	33.1	750	29.5
	8"	195	8.0	280	11.1	540	21.3	450	17.7
10 kHz	10"	236	10.0	455	17.9	540	21.3	450	17.7
	8"	195	8.0	280	11.1	540	21.3	450	17.7
15 kHz	10"	236	10.0	455	17.9	440	17.3	350	13.8
	8"	195	8.0	280	11.0	440	17.3	350	13.8
20 / 30 kHz	4"	98.5	4.0	280	11.0	390	15.4	300	11.8
30 / 40 / 50 kHz	4"	98.5	4.0	280	11.0	350	3.8	260	10.2

Flanges

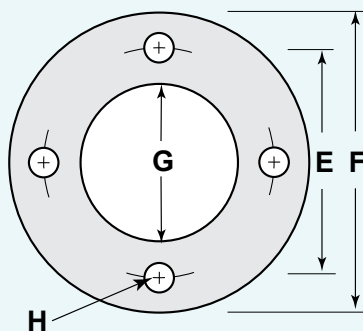

FLANGE TYPE:

- A = ANSI Flange
- J = JIS Flange
- D = DIN Flange

Standard ANSI/DN/JIS Flange Dimensions

Size	Flange Type	E (PCD)		F (OD)		G (ID)		H (Hole)		No. Holes
		mm	in.	mm	in.	mm	in.	mm	in.	
4"	FA4 ANSI class 150	190.5	7.5	229	9.0	100	4	19	0.75	8
	FD4 DIN100 PN10/16	180	7.1	220	8.7	100	4	18	0.71	8
	FJ4 JIS B2220-1984 10kg	175	6.9	210	8.4	100	4	19	0.75	8
6"	FA6 ANSI class 150	241.5	9.5	279	11.0	150	6	22	0.87	8
	FD6 DIN150 PN10	240	9.4	285	11.2	150	6	23	0.91	8
	FJ6 JIS B2220-1984 10kg	240	9.4	280	11.0	150	6	23	0.91	8
8"	FA8 ANSI class 150	298.5	11.8	343	13.5	200	8	22	0.85	8
	FD8 DIN200 PN10	295	11.6	340	13.4	200	8	22	0.85	8
	FJ8 JIS B2220-1984 10kg	290	11.4	330	13.0	200	8	19	0.91	12
10"	FA10 ANSI class 150	362	14.3	406	16.0	250	10	25	1.02	12
	FD10 DIN200 PN10	350	13.7	395	16.0	250	10	23	0.85	12
	FJ10 JIS B2220-1984 10kg	355	14.0	400	15.7	250	10	25	0.99	12

Dimensions & Wiring Diagrams

Sultan Acoustic Wave Series



Remote Amplifier

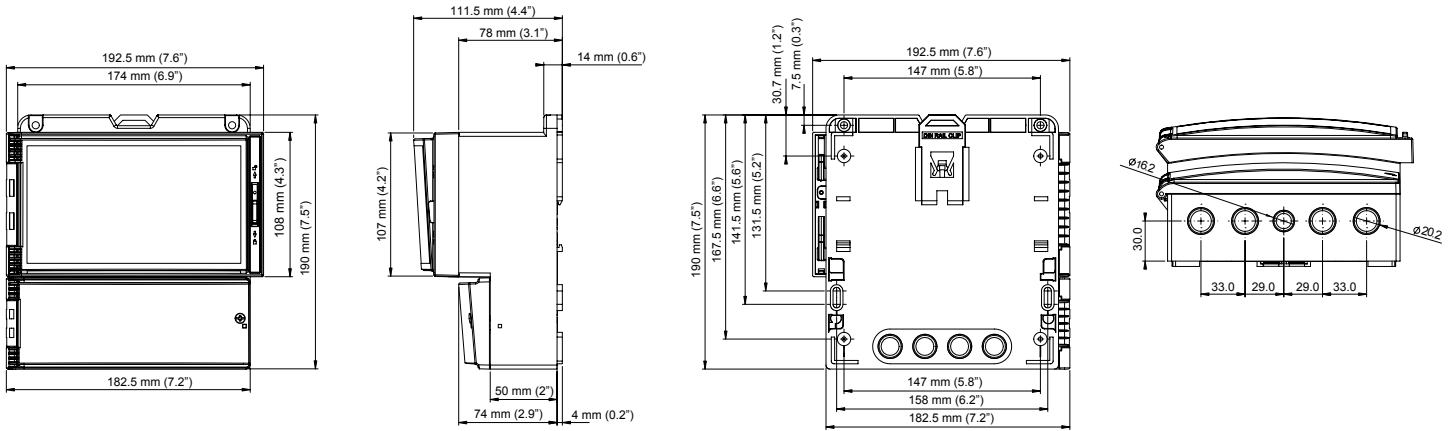

AWR Remote Transmitter

AWR234

RELAY 1			RELAY 2			RELAY 3			RELAY 4			RELAY 5		
NC	COM	NO	NC	COM	NO	NC	COM	NO	NC	COM	NO	NC	COM	NO
16	17	18	19	20	21	22	23	24	25	26	27	28	29	30
1	2	3	4	5	6	7	8	9	10	11	12	13	14	15
Is	+	-	RED	BLACK	BLUE	WHITE	Test In	B	A	-	+	⊕	N	L1
4-20mA			TRANSDUCER			COMMS			DC-In			AC-In*		

Sinking 4-20mA from user device
OR
Sourcing 4-20mA from Sultan

*48VDC Sultan version will have these terminals marked as the 30-48VDC input

AWR2

Test In		COMMS		Shld	
⊕	⊖	A	B	Shld	Shld
7	8	9	10	11	12
1	2	3	4	5	6
RED	BLACK	BLUE	WHITE	+	-
TRANSDUCER				4-20mA	

Sinking 4-20mA from user device

AWI Integral Transmitter

AWI234

RELAY 1			COMMS			RELAY 2		
NC	COM	NO	A	B	Shld	NC	COM	NO
1	2	3	4	5	6	7	8	9
L1	N	⊕	-	+	Is	Test In	-	+
AC-In			4-20mA			DC-In		

Sinking 4-20mA from user device
OR
Sourcing 4-20mA from Sultan

AWI2

COMMS		
A	B	Shld
1	2	3
-	+	Test In
4-20mA		

Sinking 4-20mA from user device

Mounting

Sultan Acoustic Wave Series



Mounting

The Transducer for both systems must be facing each other as accurately as possible. They must be completely level with the track as minor inclines or declines over long range can affect unit performance.

Avoid any flat reflective structure close to path between the Transducers as they will reflect acoustic energy and potentially cause erroneous readings. It is better to mount at a higher point to avoid track, rails, walkways etc.

Maintenance

If the Transducers are mounting horizontally, the Focalizer Cone may begin to fill with material in dusty environments. Monitor the Focalizer Cones over time and implement a cleaning schedule if required.

Setup Instruction

Sultan Acoustic Wave Series



Setup Instruction - 'Master' System

App Type (Quickset menu)

The 'Master' system is a standard Sultan Acoustic System programmed to '**Position**' Application Type (**App Type**).

The application speeds named **Fill** and **Empty** speed relate to the movement speed of the application. Fill is when the distance between the two systems is reducing, and Empty is the speed at which the distance is increasing.

The pre-set speed options are as follows (dependant on display Unit selection):

Fast	4000 metres / 13120 feet per hour
Medium	2000 metres / 6560 feet per hour
Slow	1000 metres / 3280 feet per hour

A '**Custom**' value can also be programmed if there are any problems with the above pre-sets.

Hi / Lo Level (Quickset menu)

The Hi level represents the near distance (by default the 20mA reading). The Lo level indicates the far distance (by default 4mA reading). For low frequency transducers (15, 10, 9, 5, 4kHz) we recommend avoiding a Hi level of less than 3m (10ft).

Blanking (Advanced menu)

For safety margin, increase Blanking to 2.5m (however Blanking cannot be less than the High Level value).

Gain4 (Advanced menu)

Depending on application conditions the unit may need to be more sensitive to the return echoes from the Slave. To test this you should run the machine to the maximum range of the application and confirm the Slave system is pulsing. If the Slave system is not pulsing then this indicates it is not 'hearing' the Master. In order to choose the correct value, the Slave system should first be adjusted.

Setup Instruction - 'Slave' System

Gain4 (Advanced menu)

Continuing from the above, if at maximum required range the Slave system is not pulsing then Gain4% will need to be increased. Gain4 is located in the 'Advanced' menu. Increase Gain4 by 3% increments, pressing RUN to return the unit to operating mode with each increment to see if the unit responds. Once pulsing, increase by additional 3% for safety margin and note the Gain4 value. Return to the 'Master' system and input this value.

Blanking (Advanced menu)

For safety margin, increase Blanking to 2.5m.

System Re-start

After adjusting the above parameters, we recommend re-starting (power cycle) the Master system to allow it to begin functioning fresh with the adjusted parameters.



Sultan Remote Transmitter

Model

AWR234 Remote 2 / 3 / 4 Wire, 5 relays, Modbus

Housing

S Polycarbonate

Power Supply

B 12-30VDC

C 30-48VDC and 48-90VAC

U 12-30VDC and 90-260VAC

Additional Communications (PC comms GosHawk standard)

S Switch only. 5 relays

W Modbus only

X 4-20mA analogue

I 4-20mA analogue with HART Isolated 4 wire

A Profibus PA

P Profibus DP

F Foundation Fieldbus

D DeviceNet

This option is no longer available

X Option no longer available

Approval Standard

X Not Required

A22 ATEX Grp II Cat 3 GD T85°C IP67 Tamb -40°C to 70°C

GP CSA Equip Class 2; Pollution deg 2; Tamb -20°C to 75°C (Ordinary Locations)

Position Slave / Crane Master

X Not Required

PS Position Slave

CM Crane Master

AWR234 S U X X X X



Sultan Remote Transducer 3" and 3.5"

Model

AWRT Acoustic Wave Remote Transducer

Transducer Frequency

- 30 30kHz for applications up to 15m for 3" (Cone required¹)
- 20 20kHz for applications up to 20m, 3" only (Cone required¹)
- 15 15kHz for applications up to 30m, 3" only (Cone required¹)
- 10 10kHz for applications up to 40m, 3.5" only (Cone required¹)
- 09 9kHz Positioning / Position Slave applications up to 195m (Cone required¹)
- 05 5kHz for applications up to 60m, 3.5" only (Cone required¹)
- 04 4kHz Positioning / Position Slave applications up to 195m (Cone required¹)

Process Temperature - Facing material selection

- S² Polyolefin 80°C (176°F)
- T³ Teflon 80°C (176°F)
- Y⁴ Titanium 80°C (176°F)

Transducer Housing Material

- 4 Polypropylene

Back Cap Mounting Thread Standards

- X Not Required (Standard Flange Mount)
- TB BSP

Back Cap Mounting Thread Sizes

- X Not Required (Standard Flange Mount)
- 30⁵ 3" BSP
- 50⁶ 3.5" BSP

Approval Standard

- X Not Required
- i0 IECEx Zone 0 Ex ia IIA T4 IP67 Tamb -20°C to 70°C
- A0 ATEX Grp II Cat 1 GD IP67 EEx ia IIA T4
- i1 IECEx Zone 1 and 21 Ex mb II IP68 T5(Tamb -20°C to 65°C) T6(Tamb -20°C to 50°C)
- A1 ATEX Grp II Cat 2 GD EEx m II IP68 T5(Tamb -20°C to 65°C) T6(Tamb -20°C to 50°C)
- i20 IECEx Zone 20 DIP A20 TA85C IP68 Tamb -20°C to 75°C
- A20 ATEX Grp II Cat 1 D T85°C IP67 Tamb -20°C to 75°C
- A22 ATEX Dust (Grp II Cat 3 D T85C IP67)
- GP CSA Equip Class 2; Pollution deg 2; Tamb -20°C to 75°C (Ordinary Locations)
- RN CSA Class I; Div 1/2; Group D; Zone 0; AEx / Ex ia IIA; T4
- KN CSA Class II; Div 2; Group F&G; Class III; T6 T85 for Tamb -20°C to 75°C
- QN CSA Class II; Div 1; Group E, F&G; Ex mb II; T5(T100) for Tamb -20°C to 65°C; T6(T85) for Tamb -20°C to 50°C

Connection

- C IP68 Sealed unit with cable

Cable Length

- 6 6m cable
- 15 15m cable
- 30 30m cable
- 50 50m cable

Mounting Accessories

- X Not Required
- CS⁶ End Cap Cable Suspension

Software Options

- X Not Required
- FP⁶ Fast Pulsing
- PS Position Slave (Requires Position Slave Amplifier)

¹ See Transducer / Cone / Flange combination table

² Transducer Frequency 04, 05, 09, 10 only

³ Transducer Frequency 10, 15, 20, 30 only

⁴ Transducer Frequency 15 only

⁵ Transducer Frequency 15, 20, 30 only

⁶ Transducer Frequency 04, 05, 09, 10

⁷ Transducer Frequency 30, 20 only

AWRT 10 T 4 X X X C 6 X X



Sultan Remote Transducer 2"

Model

AWRT Acoustic Wave Remote Transducer

Transducer Frequency

- 50 50kHz for liquid applications up to 5m (Cone required¹)
- 40 40kHz for liquid applications up to 7m (Cone required¹)
- 30 30kHz for liquid applications up to 11m (Cone required¹)

Process Temperature - Facing material selection

- T Tefzel 80°C (176°F)

Transducer Housing Material

- 6 Tefzel

Thread Standard

- TB BSP
- TN NPT

Thread Size

- 20 2" thread

Approval Standard

- X Not Required
- i0 IECEx Zone 0 Ex ia IIA T4 IP67 Tamb -20°C to 70°C
- A0 ATEX Grp II Cat 1 GD IP67 EEx ia IIA T4
- i1 IECEx Zone 1 and 21 Ex mb II IP68 T5(Tamb -20°C to 65°C) T6(Tamb -20°C to 50°C)
- A1 ATEX Grp II Cat 2 GD EEx m II IP68 T5(Tamb -20°C to 65°C) T6 (Tamb -20°C to 50°C)
- i20 IECEx Zone 20 DIP A20 TA85C IP68 Tamb -20°C to 75°C
- A20 ATEX Grp II Cat 1 D T85°C IP67 Tamb -20°C to 75°C
- A22 ATEX Grp II Cat 3 GD T85°C IP67 Tamb -40°C to 70°C
- GP CSA Equip Class 2; Pollution deg 2; Tamb -20°C to 75°C (Ordinary Locations)
- RN CSA Class I; Div 1/2; Group D; Zone 0; AEx/Ex ia IIA; T4
- KN CSA Class II; Div 2; Group F&G; Class III; T6 T85 for Tamb -20°C to 75°C
- QN CSA Class II; Div 1; Group E, F&G; Ex mb II; T5(T100) for Tamb -20°C to 65°C; T6(T85) for Tamb -20°C to 50°C

Connection

- C IP68 Sealed unit with cable

Cable Length

- 6 6m cable
- 15 15m cable
- 30 30m cable
- 50 50m cable

Mounting Accessories

- X Not Required
- CS Cable Suspension on end cap

Software Options

- X Not Required
- PS Position Slave

AWRT 30 T 6 TB 20 X C 6 X X

¹ See 'Transducer / Cone / Flange combination table'



Sultan Integral 3" and 3.5"

Model

AWI234 Integral 2 / 3 / 4 Wire, 2 relays, Modbus

Housing

S Valox 357U

Power Supply

B 12-30VDC

U 12-30VDC and 90-260VAC

Transducer Frequency

30 30kHz for applications up to 11m for 2" and 15m for 3" (Cone required⁶)

20 20kHz for applications up to 20m, available in 3" only (Cone required⁶)

15 15kHz for applications up to 30m, available in 3" only (Cone required⁶)

10 10kHz for applications up to 40m, available in 3.5" only (Cone required⁶)

09 9kHz for Positioning / Position Slave applications up to 180m (Cone required⁶)

05 5kHz for applications up to 60m, available in 3.5" only (Cone required⁶)

04 4kHz for Positioning / Position Slave applications up to 180m (Cone required⁶)

Process Temperature - Facing material selection

S² Polyolefin 80°C (176°F)

T³ Teflon 80°C (176°F)

Y⁴ Titanium 80°C (176°F)

Transducer Housing Material

4 Polypropylene

This option is no longer available

X Option no longer available

This option is no longer available

X Option no longer available

Additional Communication

S Switch only. 2 relays

W Modbus only

X 4-20mA analogue

I 4-20mA analogue with HART Isolated 4 wire

A Profibus PA

F Foundation Fieldbus

Approval Standard

X Not Required

A22 ATEX Grp II Cat 3 GD T85°C IP67 Tamb -40°C to 70°C

Software Options

X Not Required

PS Position Slave

AWI234 S U 10 S 4 X X X X X

² Transducer Frequency 04, 05, 09, 10 only

³ Transducer Frequency 10, 15, 20, 30 only

⁴ Transducer Frequency 15 only

⁶ See Transducer / Cone / Flange combination table



Sultan Integral 2"

Model

AWI234 Integral 2 / 3 / 4 Wire, 2 relays, Modbus

Housing

S Valox 357U

Power Supply

B 12-30VDC

U 12-30VDC and 90-260VAC

Transducer Frequency

50 50kHz for liquid applications up to 5m (Cone required⁶)

40 40kHz for liquid applications up to 7m (Cone required⁶)

30 30kHz for liquid applications up to 11m (Cone required⁶)

Process Temperature - Facing material selection

T Tefzel 80°C (176°F)

Transducer Housing Material

6 Tefzel

Thread Standards

TB BSP

TN NPT

Mounting Thread Sizes

20 2" thread

Additional Communication

S Switch only

W Modbus only

X 4-20mA analogue

I 4-20mA analogue with HART Isolated 4 wire

A Profibus PA

F Foundation Fieldbus

Approval Standard

X Not Required

A22 ATEX Grp II Cat 3 GD T85°C IP67 Tamb -40°C to 70°C

Software Options

X Not Required

PS Position Slave

AWI234 S U 40 T 6 TB 20 X X X

⁶ See Transducer / Cone / Flange combination table

Part Numbering

Sultan Acoustic Wave Series



Flange Selection

F Flange

Dimension Standard

- A ANSI²
- D DN²
- J JIS²

Flange Sizes

- 2N Matches 2" NPT threaded units
- 2B Matches 2" BSP threaded units
- 3 3" acoustically isolated flange
- 4 4" acoustically isolated flange
- 6 6" acoustically isolated flange
- 8 8" acoustically isolated flange
- 10 10" acoustically isolated flange

Flange Mounting Position¹

- A Cone Mounted (standard)
- C Angled flange piece only

Flange Material

- 4 Polypropylene

F A 4 A - 4

Additional Flange Options¹

- FA8A-4-C4** 8" ANSI, polypropylene
- FA10A-4-C4** 10" ANSI, polypropylene
- FA6D50-4** 6" ANSI, polypropylene
- FA8D50-4** 6" ANSI, polypropylene
- FA10D50-4** 6" ANSI, polypropylene

¹ Important: See Transducer / Cone / Flange combination table for valid part combinations

² See 'Flange Dimension Standards' table for full Flange specification

Transducer / Cone / Flange Combination Table

• Each line represents fitting combinations. Flange Dimension Standard A, D or J replaces underscore (_) position

Transducer	Cone	Flange Option 1	Flange Option 2	Flange Option 3	Flange Option 4
50 / 40kHz	C02	F_3A	F_4A		
30kHz (T6)	C02	F_3A	F_4A		
30kHz (T4)	C03-4-Z	F_3A			
	C04	F_3A	F_4A	F_6A	F_8A-4-C4
Back Cap Mount (TB30)		F_4A	FA6A		
20kHz	C03-4-Z	F_3A			
	C04	F_3A	F_4A	F_6A	F_8A-4-C4
Back Cap Mount (TB30)		F_4A	F_6A		
15kHz	C04	F_4A	F_6A		
	C08	F_8A	F_10A	F_6D50-4	
	C10	F_8A	F_10A	F_6D50-4	
Back Cap Mount (TB30)		F_4A	F_6A		
9 / 10kHz	C08	F_8A	F_10A	F_6D50-4	
	C10	F_8A	F_10A	F_6D50-4	
Back Cap Mount (TB50)		F_6D50-4	F_8D50-4	F_10D50-4	
4 / 5kHz	C08	F_8A	F_10A	F_6D50-4	
	C10	F_8A	F_10A	F_6D50-4	
Back Cap Mount (TB50)		F_6D50-4	F_8D50-4	F_10D50-4	

Not Recommended

Cone Selection

C Focaliser Cone

Cone Type¹

- 02N C04 cone for 2" NPT transducer
- 02B C04 cone for 2" BSP transducer
- 04 4" cone for 20kHz and 3" 30kHz transducers
- 08-15 8" cone for 15kHz
- 08-10 8" cone for 10kHz
- 10-15 10" cone for 15kHz
- 10-10 10" cone for 10kHz and 9Hz
- 10-05 10" cone for 5kHz and 4kHz

Cone Material

- 4 Polypropylene
- 7A Carbon Fibre. Includes matching ANSI Flange (4", 8" or 10")
- 7D Carbon Fibre. Includes matching DN Flange (4", 8" or 10")
- 7J Carbon Fibre. Includes matching JIS Flange (4", 8" or 10")
- 8 Polyurethane

C 04 - 4

Additional Cone Options¹

- C04-4-ZOD90** C04-4 trimmed to fit 90mm ID nozzle.
- C03-4-Z** Cone and coupling to fit 72mm ID nozzle for 20kHz and 30kHz (T4).

Accessories

HAWKLink Data Modem

Model

- HLR Remote stand alone HAWKLink system

Power Supply

- B 12-30VDC
- U 12-30VDC and 90-260VAC

Network Type

- G3 3G Autoband

Sim Card

- S3 Australian Sim Card expires after 3 month
- S12 Australian Sim Card expires after 12 month
- X Not Required

HLR U G3 S3

HAWKLink USB PC connector for GosHawkII

HAWKLink-USB

Stainless Steel Sunhood

SUNHOOD

Junction Box for twin Transducer applications

AWRT-JB-01

AWRT-JB-06 (includes 6m cable)

Extra Cable (Belden 3084A)

- CA-TXCC-R-C15** 15m cable
- CA-TXCC-R-C30** 30m cable
- CA-TXCC-R-C50** 50m cable
- CA-TXCC-R-C100** 100m cable

Specifications

Sultan Acoustic Wave Series



Frequency

- 4kHz, 5kHz, 9kHz, 10kHz, 15kHz, 20kHz, 30kHz, 40kHz, 50kHz (4kHz & 9kHz are special long range versions).

Operating Voltage

- 12 - 30VDC (residual ripple no greater than 100mV)
- 90 - 265VAC 50 / 60Hz
- 48VDC, 48VAC - 90VAC 50 / 60Hz.

Power Consumption

- <3W @ 24VDC
- <10VA @ 240VAC
- <4W @ 48VDC, <7VA @ 48VAC - 90VAC.

Analogue Output

- 4 -20mA
- Recommended 250 ohms with 24VDC supply, max. 750 ohms.

Communications

- GosHawk, HART, Modbus, Profibus PA, Profibus DP, DeviceNet, Foundation Fieldbus
- Multidrop mode can address 1 - 250 units over 4 wires.

Relay Output: (2) Integral (5) Remote

- Form 'C' (SPDT) contacts, rated 0.5A at 240VAC non-inductive
- All relays have independently adjustable dead bands
- Remote failsafe test facility for one relay.

Blanking Distance

- 50kHz = 0.25 m (10")
- 40kHz = 0.30 m (12")
- 30kHz = 0.35 m (14")
- 20kHz = 0.45 m (17")
- 15kHz = 0.60 m (24")
- 10 / 9kHz = 1.0 m (39")
- 5 / 4kHz = 1.5 m (59")

Maximum Range

- 5 m (16ft) 50kHz
- 7 m (22ft) 40kHz
- 11 m (33ft) 30kHz
- 20 m (65ft) 20kHz
- 30 m (98ft) 15kHz
- 40 m (165ft) 10kHz
- 60 m (196ft) 5kHz
- 195 m (640ft) 4 / 9kHz for extended range

Resolution

- 1 mm (0.04") 50, 40, 30, 20, 15, 10, 5kHz
- 4 mm (0.2") 9, 4kHz.

Sensor Accuracy

- +/- 0.25% of measured range.

Operating Temperature

- Integral System -40°C (-40°F) to 80°C (176°F)
- Remote Electronics -40°C (-40°F) to 80°C (176°F)
- Remote Transducer -40°C (-40°F) to 80°C (176°F).

Transducer / Amplifier Separation

- Up to 1000m using specified extension cable.

Cable

- 4 conductor shielded twisted pair instrument cable
- Conductor size dependent on cable length
- BELDEN 3084A, DEKORON or equivalent
- Max: BELDEN 3084A = 500m (1640 ft)
- Max: DEKORON IED183AA002 = 350m (980 ft).

IMPORTANT
"USE SPECIFIED
CABLE ONLY"

Maximum Operating Pressure

- +/- 7.5 PSI (+/- 0.5 Bar).

Beam Angle

- 7.5° without focaliser 50kHz / 40kHz / 30kHz
- 4° with focaliser 50kHz / 40kHz
- 6° with focaliser 30kHz / 20kHz / 15kHz / 10kHz / 5kHz
- 10° with focaliser 9kHz / 4kHz

Display

- 2 line x 12 digit alphanumeric LCD.

Memory

- Non-Volatile (No backup battery required)
- >10 years data retention.

Enclosure Sealing

- Integral System IP67
- Remote Electronics IP65 (Nema 4x)
- Remote Transducer IP68.

Cable Entries

- Integral: 3 x M16 Glands
- Remote: 3 x 20mm, 1 x 16mm knock outs.

Mounting

- ANSI, JIS or DIN Flange
- 4 in / 100mm to 10 in / 250mm
- 2in BSP Thread / NPT Thread.

Typical Weight

Sultan System with appropriate flange and cone

Frequency	kg	lb
4 or 5kHz Transducer	13	28.6
9 or 10kHz Transducer	10	22.0
15kHz Transducer	8	17.6
20 or 30kHz (3") Transducer	3	6.6
30, 40 or 50kHz (2") Transducer	1	2.2
Configuration	kg	lb
Remote Amplifier with 6m cable	1	2.2
Remote Amplifier with 15m cable	3	6.6
Remote Amplifier with 30m cable	6	13.2
Remote Amplifier with 50m cable	10	22.0

Hawk Measurement Systems

(Head Office)

15 - 17 Maurice Court
Nunawading VIC 3131, AUSTRALIA

Phone: +61 3 9873 4750

Fax: +61 3 9873 4538

info@hawk.com.au

For more information and global representatives: www.hawkmeasure.com

Additional product warranty and application guarantees upon request.

Technical data subject to change without notice.

Hawk Measurement

96 Glenn Street
Lawrence, MA 01843, USA

Phone: +1 888 HAWKLEVEL (1-888-429-5538)

Phone: +1 978 304 3000

Fax: +1 978 304 1462

info@hawkmeasure.com

Represented by:

