

Introduction

The electromagnetic flowmeter uses Faraday’s Law of electromagnetic induction to measure the process flow. The device consists of two units: a detector, through which the fluid to be measured flows and in which low-level signals proportional to flow rates are obtained; and a converter, which supplies excitation current to the detector, and amplifies the signals from the detector and then processes and converts the signals into the 4–20mA dc current signal or communication signal. Combined with a multi-functional converter LF620 (combined type) or LF622 (separate type) equipped with its original patented **Noise-Sentry** noise-suppression circuit and advanced algorithms. The GF630 has a very high tolerance to noise, giving the unit a very stable output even for slurry fluid measurement. IR (Infrared) switches enable the parameter setting of the converter without removing the cover. Flow direction can be set in either way, and its unique 128 x 128 dot matrix LCD display allows the LCD to be rotated electronically to 90, 180 and 270 degrees without opening the cover. The terminal block in LCD side make easy to wire in case of the combined type.

*1: HART protocol (Highway Addressable Remote Transducer) is a communication protocol for industrial sensors recommended by the HCF (HART Communication Foundation).

** DevComm2000 Smart Device Communicator available for performing HART device configurations on PC or laptop is available through the supplier.

*2: PROFIBUS is the communication protocol for factory and process automation that the PROFIBUS Organization recommends. Instead of analog control with a conventional analog signal (4-20mA), it is the fieldbus which digitizes all signals. Flowmeters support PROFIBUS-PA.

* Modbus is the communication protocol that Modicon Inc. developed. Physical layer is RS485.

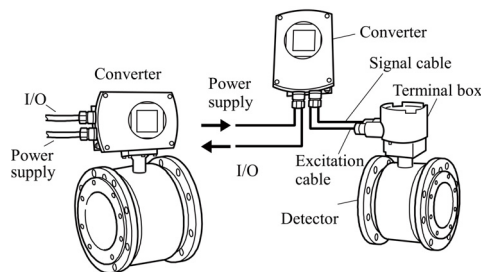

Combined type
GF630/LF620
GF630/LF620F

Separate type
GF632/LF622
GF632/LF622F

Figure 1. Configuration



Figure2. GF630 Premium Value series Flowmeters



Certification
 No.Z01207



Certification
 No. PM09896
 For PU lined flowmeter

Specifications

Overall Specifications

Measurement range in terms of flow velocity:

1.0 ft/s to 32.8 ft/s (0.3 m/s to 10 m/s).

0.3 ft/s to 1.0 ft/s (0.1 m/s to 0.3 m/s)

range is available optionally for meter size 1/2” to 18” (15 to 450 mm).

Accuracy:

< 1/2" to 18" (15 mm to 450 mm) >

±0.2 % of Rate *1.

*1 This pulse output error result is established under standard operating conditions at Toshiba’s flow calibration facility, Fuchu Japan (NIST Traceable).

*1 Individual meter measurement error may vary up to ±0.5% of Rate at 1.64 ft/s (0.5m/s) or more. Or it may vary up to ±0.3% of rate ±0.039 inch/s (1mm/s) at 1.64 ft/s (0.5m/s) or less.

*1 Current output: plus ± 8µA (0.05% of span).

*1 Refer to individual calibration data for each individual meter’s measurement error.

**< 20" and 24" (500 mm and 600 mm) >
±0.3 % of Rate ^{*2}.**

^{*2} This pulse output error result is established under standard operating conditions at Toshiba's flow calibration facility, Fuchu Japan.

^{*2} Individual meter measurement error may vary up to ±0.5% of Rate at 3.28 ft/s (1.0 m/s) or more. Or it may vary up to ±0.3% of rate ±0.079 inch/s (2 mm/s) at 3.28 ft/s (1.0 m/s) or less.

^{*2} Current output: plus ± 8µA (0.05% of span).

^{*2} Refer to individual calibration data for each individual meter's measurement error.

Fluid conductivity: 3µS/cm minimum

Fluid temperature:

-4 to 212 °F (-20 to +100 °C): FEP lining

-4 to 248 °F (-20 to +120 °C): PTFE lining

-4 to 140 °F (-20 to + 60 °C): Polyurethane lining

Ambient temperature: -4 to 140 °F (-20 to +60 °C)

Structure:

Standard — IP 67 and NEMA 4X Watertight

Option — IP68 and NEMA 6P Submersible type allows for accidental submergence up to 15m for 48 hours. This option is only available when PU liner is selected.

Power consumption:

Standard:10W(14VA)

at AC100V and Excitation current:0.2A

MAX:15W (22VA)

MAX:17W(24VA) with PROFIBUS

Approved hazardous location certifications:

Model: GF630/LF620F and GF632/LF622F

cFMus Nonincendive for use in

hazardous (classified) locations:

Class I, II, III, Division 2, Groups A-G

Drinking water approvals:

PU liner: NSF/ANSI standard 61

■ Model GF630 and GF632 Detector

Mounting style:

Flange connection type, ISO13359 for direct replacement of existing ISO13359 magmeters.

Fluid pressure:

0 psi or 0 bar (0 Pa) to the nominal pressure of the connection flange

Note: Before shipping from the manufacturer, each detector unit is tested by following test condition.

Pressure... twice of the pressure index number

(ex. 300 psi in ASME B 16.5 class 150 case)

Time... 5 minutes

Connection flange standards:

ASME B 16.5 class 150 : 1/2" to 24" (15 to 600 mm)

JIS B 2220 10K : 1/2" to 24" (15 to 600 mm)

Principal materials:

Case — carbon steel

Flange material — carbon steel

Linings —

FEP: Meter sizes 1/2" to 10" (15 to 250mm)

PTFE: Meter sizes 12" to 24" (300 to 600mm)

Polyurethane (PU) with NSF approval:

Meter sizes 1/2" to 18" (15 to 450mm)

Polyurethane (PU)

Meter sizes 1/2" to 16" (15 to 400mm)

Electrodes —

Type - Super smooth, polished with self cleaning finish, and non stick shape.

316L stainless steel (for PU lining).

Hastelloy C equivalent (for FEP, PTFE lining).

Measuring tube material — 304 stainless steel

Terminal box — Aluminum alloy (for separate type)

Grounding ring —

PU, FEP lining:

None (std.), 316 stainless steel (opt.)

PTFE lining: 316 stainless steel (std.)

Coating: Corrosion resistant resin coating (std.), pearl-gray colored

Dimensions and weights: See Figure 3 and 4.

Cable connection port: for separate type detectors.

Applicable diameter —

0.433 to 0.512 inch (11 to 13mm)

Cable glands —

GF632 without cFMus Approval:

Provided as standard, G1/2 male threads.

GF632 with cFMus Approval:

Not provided, 1/2-14NPT male threads are required.

■ Model LF620 and LF622 converters

Input signals

Analog signal — the voltage signal from detector, proportional to process flow rate (for LF622 separate type converter).

Digital input DI

Signal type: 20 to 30Vdc voltage signal
Input resistance: 2.7k Ω
Number of inputs: one point

DI function — One of the following functions can be assigned to the optional DI signal.

Range switching — Selects either the higher or lower range in the unidirectional or bidirectional 2-range setting.

Totalizer control — Starts and stops the built-in totalizer.

Fixed-value outputs — Outputs fixed-values for current and pulse outputs.

Zero adjustment — Executes zero adjustment (on-stream at zero flow rate).

Output signals

Current output:

4–20 mAdc (load resistance 0 to 750 Ω)

Note: The current output cannot be used with the PROFIBUS-PA communication.
(Refer table 8 for details)

Digital outputs — Two points are available as follows..

Digital output DO1:

Output type: Transistor open collector
Number of outputs: One point
Output capacity: 30Vdc, 200mA maximum

Note: DO1 cannot be used if Modbus communication connection is 3 lines.
(Refer table 8 for details)

Digital output DO2:

Output type: Solid-state relay output
(non polarity)
Number of outputs: One point
Output capacity: 150Vdc, 150mA maximum
or 150Vac (peak to peak), 100mA maximum

Note: DO2 cannot be used with the Modbus communication. (Refer table 8 for details)

DO1 and DO2 functions — One of the following functions can be assigned to DO1 and/or DO2.

• Pulse output (available only for DO1,DO2)

Pulse rate: Max 10kHz (10,000pps)(DO1)
Max 100Hz (100pps) (DO2)
(Over 1kpps, auto-setting)

Pulse width: 0.5 to 500ms (but less than half of the period for 100% flow rate)

Note: The same and simultaneous pulse is not available between DO1 and DO2.

- **Multi-range selection outputs (Note 1)**
- **High, High high, Low, and/or Low low alarm outputs (Note 2)**
- **Empty pipe alarm output (Note 2)**
- **Preset count output**
- **Converter failure alarm output**

Note 1: Two outputs (DO1 and DO2) are needed for 4-range switching and forward/reverse 2-range switching.

Note 2: Normal Open (default set) or Normal Close is selected for alarm outputs when programming.
When power failure occurs, unit will be fault to Normal Open.

Communications output:

- **HART (std.)** — Digital signal is superimposed on 4–20mAdc current signal as follows:
Conforms to HART protocol
Load resistance: 240 to 750 Ω
Load capacitance: 0.25 μ F maximum
Load inductance: 4mH maximum
- **PROFIBUS (opt.)**
Protocol: PROFIBUS-PA
Baud rate: 31.25kbps
Bus voltage: 9-30VDC
Consumption electric current of bus:
Less than 16mA
Manufacture Ident-No.: 093B_{HEX}
Standard Ident-No.: 9740_{HEX}
Slave address: 0-126 (Default address is 126)
Profile: Profile Ver.3.01 for Process Control Devices
Function blocks: AI(Flow) \times 1 , Totalizer \times 1
- **MODBUS (opt.)**
Physical layer : RS485
Protocol : Modbus
Mode : RTU
Baudrate : 4800, 9600, 19200bps
Data length : 8bit
Parity bit : None, Odd, Even
Stop bit : 1bit, 2bit
Error check : CRC-16
Max. station number : 32(with Master device)
Max. cable length : 1.2km (Note)
Note: This length is specification of 3 line connection.

LCD display:

Full dot-matrix 128×128 dot LCD display
(back-light provided)

A parameter change will rotate the display.

Parameter settings — Parameters can be set as follows:

- **IR Switches:** Three key switches are provided to set configuration parameters.
- **Digital communication:** HART, PROFIBUS or Modbus is needed to set parameters.
- **Zero adjustment:** Zero point adjustment can be started by pressing the switch in the converter.
- **Damping:** 0.5 to 60 seconds (selectable in one second increments)

“Field re-verification” Mag-Prover – Toshiba’s Zero span calibration tool allows unit to be re-calibrated and verified using an internal software program (For more information contact Toshiba International Corp.)

Conditions when power fails:

Parameter setting values are stored in non-volatile memory and the values will be restored when the power returns to normal condition. The outputs and display will remain as follows when power fails.

- Current output: 0mA_{dc}
- Digital output: OFF
- LCD display: No display
- PROFIBUS: No communication

Power supply:

One of the following can be selected:

- 100 to 240Vac, 50/60Hz
(allowable voltage 80 to 264Vac)
110Vdc
(allowable voltage 90 to 130Vdc)
- 24Vdc (allowable voltage 18 to 36Vdc)

Surge protection:

Arresters are installed in the power supply and a current signal output circuit to help protect the meter from lightning and improve personnel safety.

Case: Aluminum alloy (equal to IP 67)

Coating: Acrylic resin-baked coating, pearl-gray colored

Cable connection port:**Cable glands** —

LF620 and LF622 without cFMus Approval:

Provided as standard, G 1/2 male threads.

OD of cable ϕ 11 to 13mm

Material: Nylon 66

LF620F and LF622F with cFMus Approval:

Not provided, 1/2–14NPT male threads are required.

Applicable diameter —

0.433 to 0.512 inch (11 to 13mm)

Note: When PROFIBUS option is specified, cable gland size is ϕ 6~8mm for signal cable, ϕ 11~13mm for power cable.

Vibration resistance:

No resonance to the following levels of vibration:

- 10 to 150Hz with acceleration of 9.8m/s²
- Vibration of 30Hz with 29.4 m/s² in 4h in each direction will not cause any defect to unit.

Note: Avoid using the flowmeter in an environment with constant vibration.

Converter LF622 Dimensions and Weights:

See Figure 5 (for separate type)

MTBF:

Converter: 220,000 hours (25 years) at 77 °F
(25 °C) based on strict military specification MIL-HDBK-217F.

Detector: 350,000 hours (40 years) at 77 °F
(25 °C) based on strict military specification MIL-HDBK-217F.

Installation

■ Dimensions

Combined type GF630/LF620 and GF630/LF620F

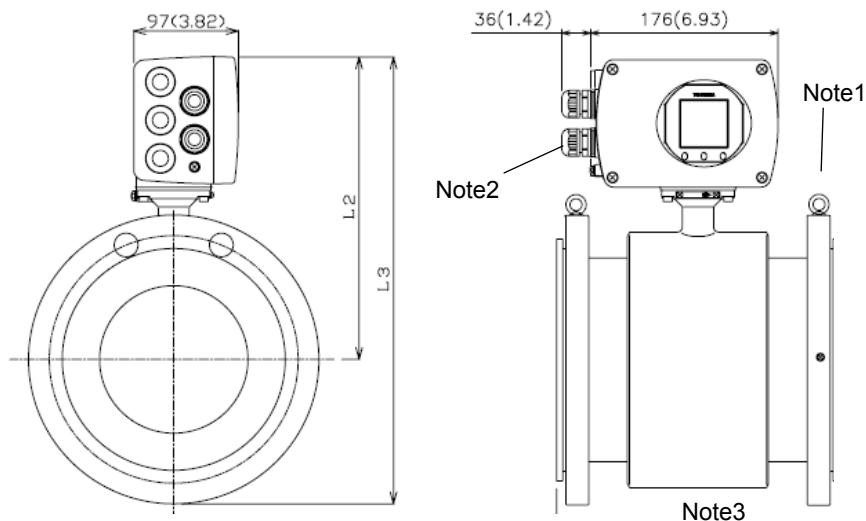

- Note1:** Eye bolts are provided at the flange for flowmeters sized 8" (200mm) or above.
- Note2:** Cable glands are not provided for GF630/LF620F cFMus approved type. Refer to the part Cable connection port at detector.
- Note3:** L1 of PTFE lining contains the thickness of grounding rings.
- Note4:** The weight of PTFE lining includes the weight of grounding rings.
- Note5:** 1 inch = 25.4mm

Unit: inch (mm)

ASME B 16.5 class 150								
Size (inch)	L1 (inch)	L2 (inch)	L3 (inch)	No. of bolts	Weight (lbs) approx.			
					FEP	PTFE	PU	
1/2	7.9	8.1	10.0	4	16		16	
1	7.9	8.5	10.9	4	18		18	
1-1/4	7.9	8.7	11.3	4	20		20	
1-1/2	7.9	8.9	11.6	4	23		23	
2	7.9	9.3	12.3	4	29		29	
2-1/2	7.9	9.8	13.2	4	34		34	
3	7.9	10.0	13.6	4	42		42	
4	9.8	10.4	14.5	8	56		56	
5	9.8	11.2	16.1	8	71		71	
6	11.8	11.8	17.3	8	84		84	
8	13.8	12.8	19.3	8	128		128	
10	17.7	13.5	21.4	12	188		188	
12	19.7	14.5	23.3	12		292	274	
14	21.7	15.4	2.05	12		349	327	
16	23.6	16.5	27.5	16		430	402	
18	23.6	17.4	29.6	16		468		
20	23.6	18.3	31.7	20		538		
24	23.6	20.5	36.2	20		741		

JIS B 2220 10K								
Size (mm)	L1 (mm)	L2 (mm)	L3 (mm)	No. of bolts	Weight (kg) approx.			
					FEP	PTFE	PU	
15	200	220	268	4	7		7	
25	200	230	293	4	8		8	
32	200	235	303	4	10		10	
40	200	240	310	4	11		11	
50	200	250	328	4	12		12	
65	200	263	350	4	15		15	
80	200	268	360	8	16		16	
100	250	279	384	8	23		23	
125	250	299	424	8	29		29	
150	300	314	454	8	34		34	
200	350	339	504	12	48		48	
250	450	359	559	12	70		70	
300	500	384	606	16		101	93	
350	550	406	651	16		137	127	
400	600	434	714	16		149	136	
450	600	456	766	20		171		
500	600	481	819	20		185		
600	600	536	934	24		253		

Figure 3. GF630/LF620 and GF630/LF620F combined type flowmeters
Meter sizes 1/2" (15mm) to 24" (600mm)

Separate type GF632/LF622 and GF632/LF622F

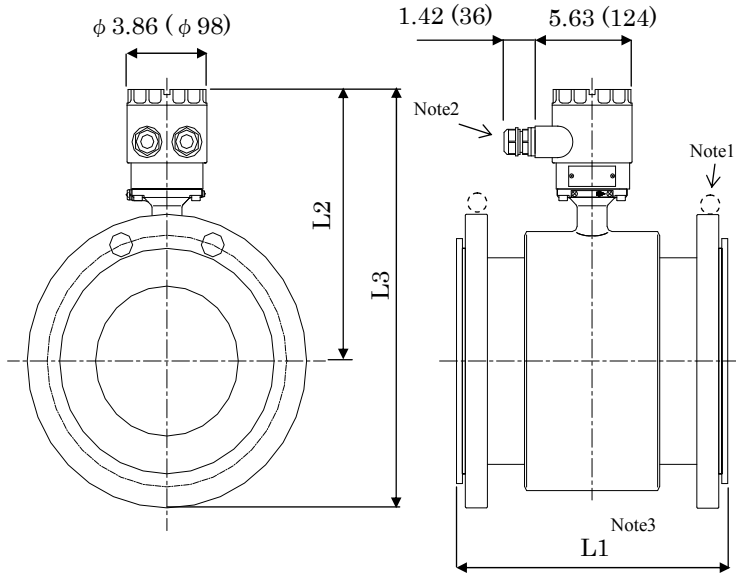

- Note1:** Eye bolts are provided at the flange for flowmeters sized 8" (200mm) or above.
- Note2:** Cable glands are not provided for GF632/LF622F cFMus approved type. Refer to the part Cable connection port at detector.
- Note3:** L1 of PTFE lining contains the thickness of grounding rings.
- Note4:** The weight of PTFE lining includes the weight of grounding rings.
- Note5:** 1 inch = 25.4mm

Unit: inch (mm)

ASME B 16.5 class 150							
Size (inch)	L1 (inch)	L2 (inch)	L3 (inch)	No. of bolts	Weight (lbs) approx.		
					FEP	PTFE	PU
1/2	7.9	4.9	8.5	4	12		12
1	7.9	5.1	9.3	4	14		14
1-1/4	7.9	5.3	9.7	4	16		16
1-1/2	7.9	5.4	10.1	4	18		18
2	7.9	5.7	10.9	4	25		25
2-1/2	7.9	6.1	11.9	4	29		29
3	7.9	6.2	12.4	4	38		38
4	9.8	6.5	13.6	8	51		51
5	9.8	7.1	14.9	8	67		67
6	11.8	7.5	15.9	8	80		80
8	13.8	8.2	18.2	8	124		124
10	17.7	8.8	20.2	12	183		183
12	19.7	9.5	22.7	12		287	269
14	21.7	10.1	24.6	12		344	322
16	23.6	10.9	26.9	16		426	397
18	23.6	11.5	28.6	16		463	
20	23.6	12.2	30.8	20		534	
24	23.6	13.8	35.2	20		737	

JIS B 2220 10K							
Size (mm)	L1 (mm)	L2 (mm)	L3 (mm)	No. of bolts	Weight (kg) approx.		
					FEP	PTFE	PU
15	200	172	220	4	5		5
25	200	182	245	4	6		6
32	200	187	255	4	8		8
40	200	192	262	4	9		9
50	200	202	280	4	10		10
65	200	215	302	4	13		13
80	200	220	312	8	14		14
100	250	231	336	8	21		21
125	250	251	376	8	27		27
150	300	266	406	8	32		32
200	350	291	456	12	46		46
250	450	311	511	12	68		68
300	500	336	558	16		99	91
350	550	358	603	16		135	125
400	600	386	667	16		147	134
450	600	408	718	20		169	
500	600	433	771	20		183	
600	600	488	886	24		251	

Figure 4. Separate type detectors GF632
Meter sizes 1/2" (15mm) to 24" (600mm)

Weight: Approx. 7 lb (3.5 kg)

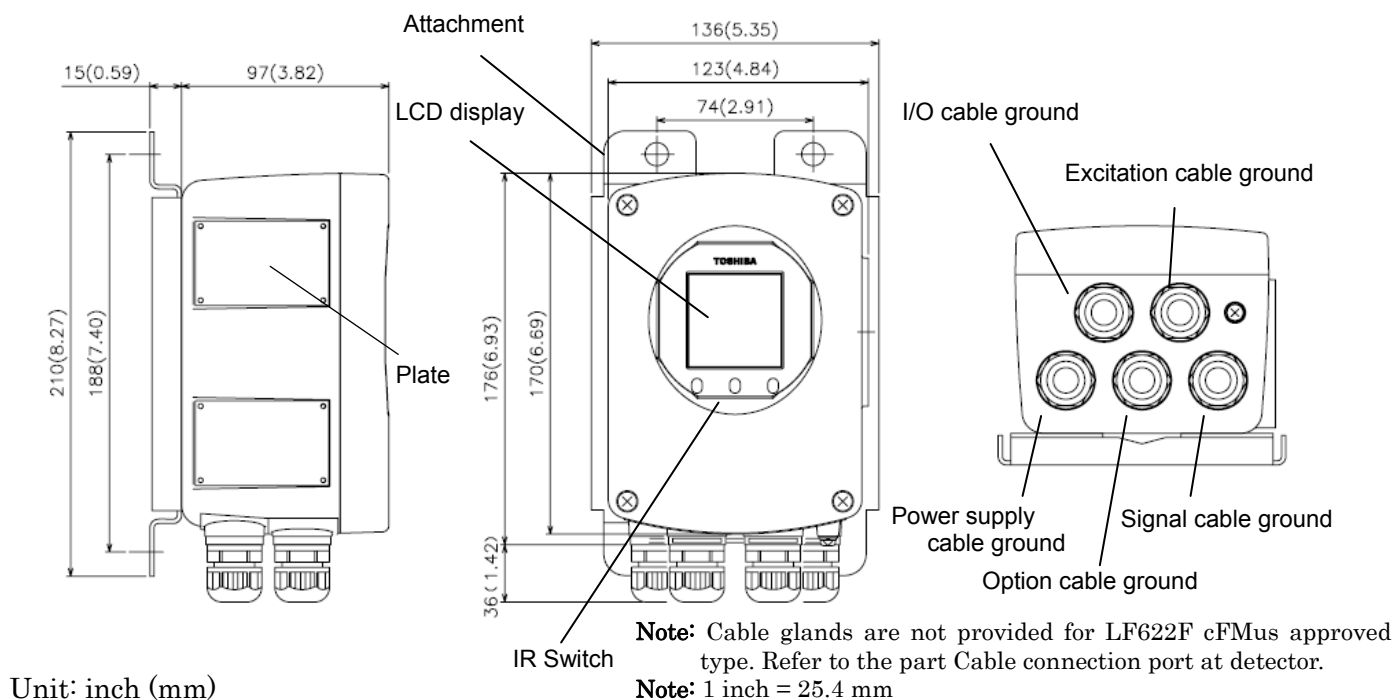

Figure 5. Separate type converter LF622 and LF622F

External Connections

Combined type GF630/LF620 and GF630/LF620F flowmeters

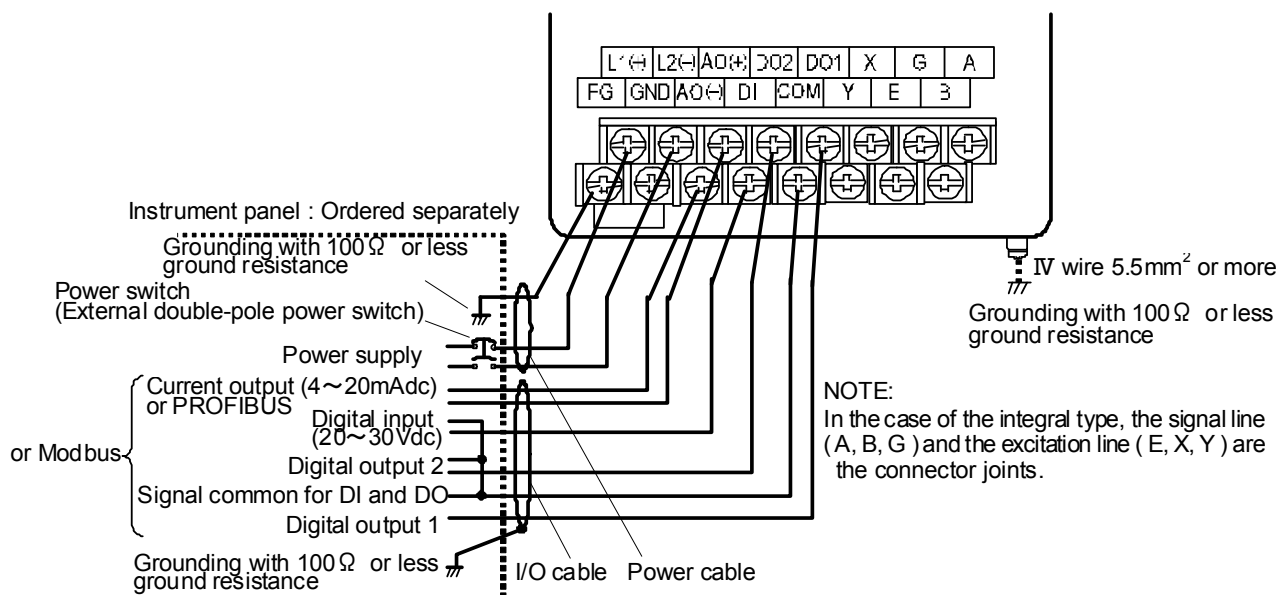

Figure 6. Combined type GF630/LF620 and GF630/LF620F flowmeters Wiring Diagram

Separate type GF632/LF622 and GF632/LF622F flowmeters

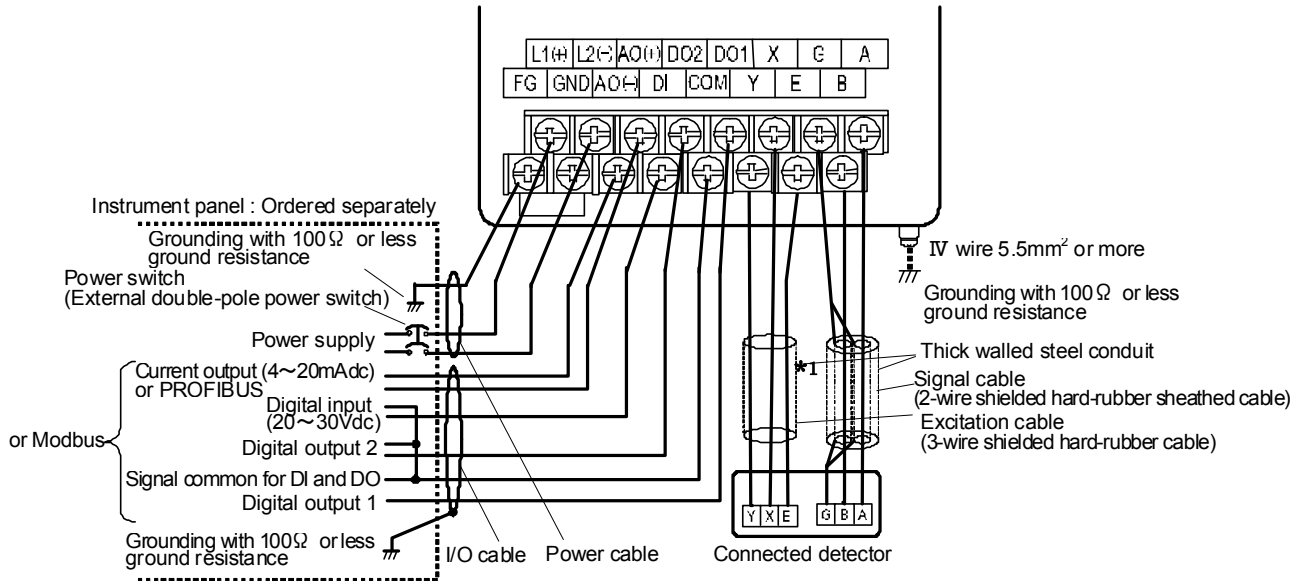

Figure 7. Separate GF632/LF622 and GF632/LF622F type Converter Wiring Diagram

Table 1. LF620, LF620F, LF622 and LF622F Converters Signal Table

Symbol	Description	Cable
L1 (+)	Power supply	Power cable
L2 (-)		
GND	Ground (for arrester)	
FG	Frame ground	
DI	Digital Input (20~30Vdc)	I/O cable
DO1	Digital Output 1	
DO2	Digital Output 2	
COM	Signal Common for DI, DO1, DO2	
+	Current Output (4~20mA dc) or PROFIBUS	Shielded cable for PROFIBUS-PA
-		
X	Excitation Output	Excitation cable (for LF622, LF622F only)
Y		
E		
A	Signal Input	Signal cable (for LF622, LF622F only)
B		
G		
T+	Modbus(+)	Twisted-pair polyethylene insulated vinyl sheath cable (JKEV, AWG24(0.2mm²))
T-	Modbus(-)	
TG	Modbus(GND)	

Note: Symbol of the terminal is changed as follows for Modbus.

DO2 → T+, DI → T-, COM → TG

■ Wiring Precautions

- (1) Explosion proof type flowmeters are not provided cable glands.
Refer to the part Cable connection port at detector and converter.
- (2) Connect the grounding wire (IV wire 5.5mm² or more) to a good earth ground (100Ω or less ground resistance). Make the wire as short as possible. Do not use a common ground shared with other equipment where earth current may flow. An independent earth ground is recommended.
- (3) The allowable cable lengths between the detector and converter for the separate type flowmeter depend on the electrical conductivity of the object fluid. See Figure 8.
- (4) DO1, DO2, and DI use the same common terminal (COM). This COM can not connect to other equipments which have their own ground terminal. (Power supply for connecting to DI or DO, etc...) Need to wire separately.

■ Wiring Precautions (PROFIBUS or Modbus)

- (1) For wiring path, avoid places near electrical equipment that may cause electromagnetic induction or electrostatic induction interference (such as a motor, transformer and wireless transmitter).
- (2) Use a PROFIBUS-PA cable for signal cable. In addition, make sure to use a shielded cable to improve noise resistance. Furthermore, installation of signal cable in metal conduit is recommended.
- (3) General PROFIBUS-PA cables are designed for indoor use where cables are not exposed to humidity, rain, etc. When you install cables, make sure to check the operating conditions such as the operating temperature range of the cable by contacting its manufacturer.
- (4) When you carry out cable end treatment of PROFIBUS-PA cable, use a dedicated cable stripper etc. so that the core wire of the cable will not be nicked or damaged. In addition, for cables, be careful of allowable maximum bend diameter etc. (Basically, do not install cables in a way cables are twisted or bent.)
- (5) Consider installing a PROFIBUS-PA arrester in the communication path of PROFIBUS-PA so that the electromagnetic flowmeter will not be affected by lightning etc.

- (6) The electromagnetic flowmeter is not equipped with terminating resistors. Use the terminating resistor unit for PROFIBUS-PA or junction box, if necessary.
- (7) Only one PROFIBUS-PA cable goes through a cable gland of the Electromagnetic Flowmeter. Use the junction box at system configuration.
- (8) Install a terminator to flowmeter that connected to end of Modbus network.

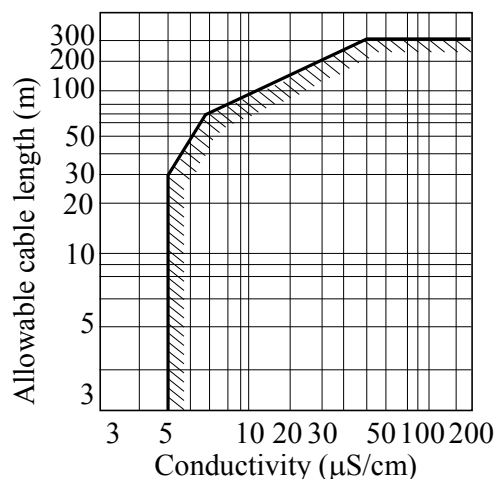

Figure 8. Electrical Conductivity and Cable Length

■ Meter Size

To select the meter size:

See Table 2 to 3 and find meter sizes within the velocity of 0.3 to 32.8 ft/s (0.1 to 10m/s) for a specified full-scale (measuring range high limit) flow. Select one that has its full-scale velocity between 3.0 and 10 ft/s (1 and 3m/s).

Note: Make sure the full-scale flow rate used for the final planning stage stays within 32.8 ft/s (10m/s) in terms of flow velocity.

**Table 2. Flow Rate and Flow velocity
(English unit)**

Unit: gal/min

Size (inch)	Flow rate				
	0.328 ft/s	0.98 ft/s	3.0ft/s	10 ft/s	32.8 ft/s
1/2'	0.2801	0.8403	2.561	8.532	28.01
1	0.7781	2.334	7.115	23.72	77.81
1 ¼	1.275	3.824	11.66	38.86	127.5
1 ½	1.992	5.975	18.21	60.71	199.2
2	3.112	9.337	28.46	94.86	311.2
2 ½	5.260	15.78	48.09	160.3	526.0
3	7.967	23.90	72.85	242.8	796.7
4	12.45	37.35	113.8	379.4	1,245
5	19.45	58.35	177.9	592.9	1,945
6	28.01	84.03	256.1	853.8	2,801
8	49.80	149.4	455.3	1,518	4,980
10	77.81	233.4	711.5	2,372	7,781
12	112.0	336.1	1,025	3,415	11,200
14	152.5	457.5	1,394	4,648	15,200
16	199.2	597.5	1,821	6,071	19,920
18	252.1	756.3	2,305	7,684	25,210
20	—	933.7	2,846	9,486	31,120
24	—	1,344	4,098	13,660	44,820

Table 3. Flow Rate and Flow velocity (SI unit)

Unit: m³/h

Size (mm)	Flow rate				
	0.1 m/s	0.3 m/s	1.0 m/s	3.0 m/s	10 m/s
15	0.06362	0.1908	0.6361	1.908	6.361
25	0.1767	0.5301	1.767	5.301	17.67
32	0.2895	0.8686	2.895	8.686	28.95
40	0.4523	1.357	4.523	13.57	45.23
50	0.7067	2.120	7.067	21.20	70.67
65	1.195	3.583	11.95	35.83	119.5
80	1.809	5.428	18.09	54.28	180.9
100	2.827	8.482	28.27	84.82	282.7
125	4.417	13.25	44.17	132.5	441.7
150	6.361	19.08	63.61	190.8	636.1
200	11.31	33.93	113.1	229.3	1,131
250	17.67	53.01	176.7	530.1	1,767
300	25.45	76.34	254.5	763.4	2,545
350	34.64	103.9	346.4	1,039	3,464
400	45.23	135.7	452.3	1,357	4,523
450	57.25	171.7	572.5	1,717	5,725
500	—	212.1	706.9	2,121	7,069
600	—	305.4	1,018	3,054	10,180

■ Piping Precautions

- (1) Design piping so that the flowmeter detector pipe is always filled with the fluid being measured, whether the fluid is flowing or not.
- (2) The detector has no adjustable piping mechanism. Install an adjustable short pipe where needed.
- (3) The required straight pipe length should comply with the requirements as follows.
- (4) Be sure to ground the flowmeter according to the flow meter instruction manual.

Required straight pipe length

Upstream side	When using 90-degree bend, tee, diffuser or fully opened valve	$L \geq 5D$
	When using other types of valves	$L \geq 10D$
Downstream side	When no valve plate protrudes into the detector pipe	$L \geq 0$

L: Required straight pipe length, D: Meter size

■ Piping materials (to be ordered separately)

Mating flanges:

The flowmeter must be mounted with its detector pipe connected between the flanges in the pipeline. If no flanges are used where the flowmeter is to be mounted, mating flanges are required.

Adjustable short pipe:

When both the upstream and downstream pipe sections cannot be adjusted laterally along the pipeline, an adjustable short pipe may be required.

Reducers:

When the flowmeter with its Meter size smaller than that of the pipeline should be installed, reducers are required on both ends of the flowmeter detector.

Reducers with pipe extensions:

Reducers with adjustable piping mechanism.

■ About establishment environment

Do not store or install the flowmeter :

- Where there is direct sunlight.
- Where excessive vibration or mechanical shock occurs.
- Where high temperature or high humidity conditions exist.
- Where corrosive atmospheres exist.
- Places that can be submerged under water.
- Where there is a sloped floor. To put the flowmeter temporarily on the floor, place it carefully with something, such as a block, to support it so that the flowmeter will not topple over.

In areas like the following, there may be the case that infrared switches do not function correctly. (If these are unavoidable, use an appropriate cover.)

- (1) Where unit (operation panel) is exposed to direct sunlight, reflection of light onto window pane and diffused light reflection.
- (2) Where smoke and steam may occur.
- (3) Where exposed to direct snow, ice or mud.

Ordering Information

1. When ordering the GF630 series flowmeters, refer to Tables 5 to 7 (Type Specification Codes). An entry must be made for each of the columns in each of these tables.
2. Fluid characteristics:
 - (1) Type of fluid to be measured and its characteristics
 - (2) Fluid temperature
 - (3) Fluid pressure
 - (4) Electrical conductivity of the fluid
3. Measuring range
4. I/O function setting
5. Ordering scope:
Flow calibration data: (required or not)
6. Other items
Specifications other than standard items

Consult a Toshiba representative when choosing materials for lining, electrodes, and grounding rings.

Toshiba International Corp. (Houston) stocks Hazardous location certification type flowmeters as standard inventory.

Ordering Grounding rings

When you purchase the grounding ring, refer to Table 4.

Note: The grounding ring ordering code includes 2-metal grounding rings.

Table 4. Ordering code of the Grounding ring

Meter size		ASME B 16.5 class 150 flange
inch	mm	
1/2	15	GFR01
1	25	GFR02
1-1/4	32	GFR03
1-1/2	40	GFR04
2	50	GFR05
2-1/2	65	GFR06
3	80	GFR08
4	100	GFR10
5	125	GFR12
6	150	GFR15
8	200	GFR20
10	250	GFR25
12	300	GFR30
14	350	GFR35
16	400	GFR40
18	450	GFR45
20	500	GFR50
24	600	GFR60

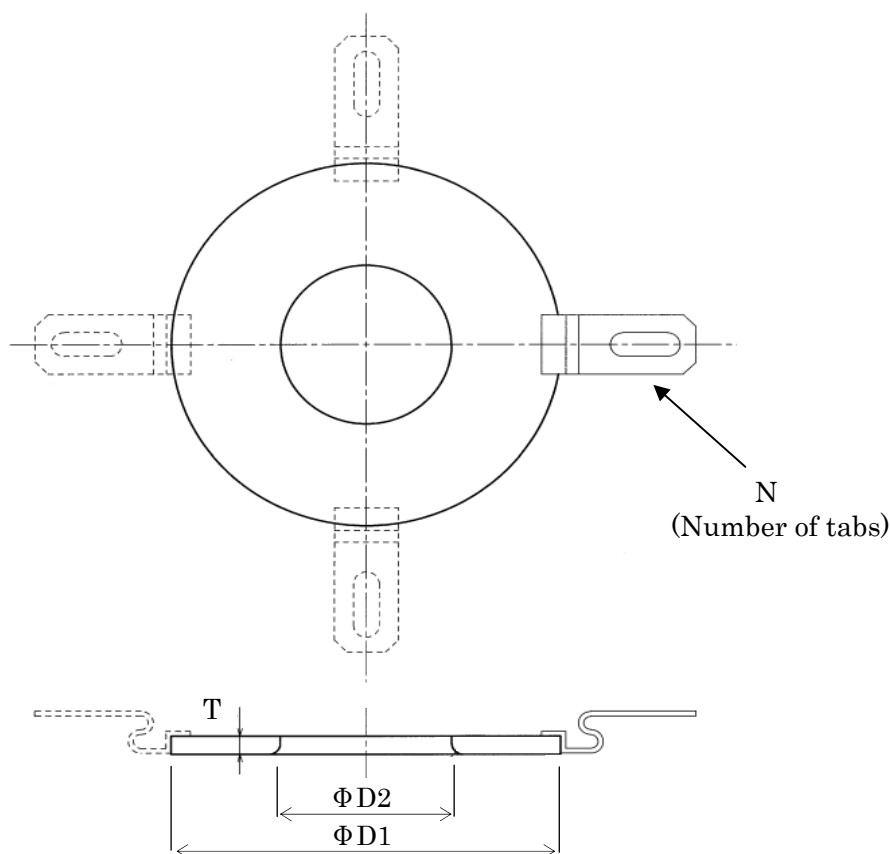

Meter size		ASME B 16.5 class 150				JIS B 2220 10K (Unit: mm)			
inch	mm	ΦD1	ΦD2	T	N	ΦD1	ΦD2	T	N
1/2	15	1.65	0.63	0.16	2	42	16	3.0	2
1	25	2.36	1.06	0.16	2	60	27	3.0	2
1-1/4	32	2.76	1.34	0.16	2	70	34	3.0	2
1-1/2	40	3.03	1.65	0.12	2	77	42	3.0	2
2	50	3.74	2.05	0.12	2	95	52	3.0	2
2-1/2	65	4.69	2.44	0.12	2	115	67	3.0	2
3	80	5.08	3.03	0.12	2	125	82	3.0	2
4	100	5.91	4.09	0.12	2	150	104	3.0	2
5	125	7.28	5.08	0.12	2	185	129	3.0	2
6	150	8.46	6.06	0.12	2	215	154	3.0	2
8	200	10.43	8.03	0.12	4	265	204	3.0	4
10	250	13.11	10.04	0.12	4	325	255	3.0	4
12	300	15.59	12.01	0.12	4	372	305	3.0	4
14	350	17.32	13.11	0.12	4	416	333	3.0	4
16	400	19.80	15.12	0.12	4	479	384	3.0	4
18	450	21.34	17.05	0.12	4	534	433	3.0	4
20	500	23.58	19.02	0.12	4	589	483	3.0	4
24	600	27.95	22.99	0.12	4	691	584	3.0	4

Figure 9. Grounding ring Meter sizes 1/2" (15mm) to 24" (600mm)

Table 5. Specification Code (Flange type detector GF630 (Combined type))

Model					Specification Code									Description	Lining			
1	2	3	4	5	6	7	8	9	10	11	12	13	14		PU	FEP	PTFE	
G	F	6	3	0											Combined (Integral) type	●	●	●
															Meter size			
					0	1									1/2" (15 mm)	●	●	-
					0	2									1" (25 mm)	●	●	-
					0	3									1-1/4" (32 mm)	●	●	-
					0	4									1-1/2" (40 mm)	●	●	-
					0	5									2" (50 mm)	●	●	-
					0	6									2-1/2" (65 mm)	●	●	-
					0	8									3" (80 mm)	●	●	-
					1	0									4" (100 mm)	●	●	-
					1	2									5" (125 mm)	●	●	-
					1	5									6" (150 mm)	●	●	-
					2	0									8" (200 mm)	●	●	-
					2	5									10" (250 mm)	●	●	-
					3	0									12" (300 mm)	●	-	●
					3	5									14" (350 mm)	●	-	●
					4	0									16" (400 mm)	●	-	●
					4	5									18" (450 mm)	●	-	●
					5	0									20" (500 mm)	-	-	●
					6	0									24" (600 mm)	-	-	●
							A								Connection flange standard			
							J								ASME B 16.5 class 150	●	●	●
															JIS B 2220 10K	●	●	●
															Lining			
							N								Polyurethane(PU) with NSF approval	●	-	-
							U								Polyurethane(PU) (Note2)	○	-	-
							F								FEP	-	●	-
							P								PTFE (Note1)	-	-	●
															Electrode Material			
							B								316L stainless steel	●	-	-
							F								Hastelloy C (Equivalent)	-	●	●
															Flow and calibration velocity range			
										A					1.0 to 32.8 ft/s (standard range calibration)	●	●	●
										B					1.0 to 32.8 ft/s (specified range calibration)	○	○	○
										C					0.3 to 32.8 ft/s (specified range calibration)	○	○	○
											1				Standard	●	●	●

Code explanation... ●: Standard ○: Option —: Not available

Note1: The grounding rings are provided to PTFE Lining, which material is 316 stainless steel and gasket material is EPDM rubber.

Note2: Meter size of Polyurethane (PU) is from 1/2”(15mm) to 16”(400mm).

Table 6. Specification Code (Flange type detector GF632 (Separate type))

Model					Specification Code									Description	Lining			
1	2	3	4	5	6	7	8	9	10	11	12	13	14		PU	FEP	PTFE	
G	F	6	3	2											Separate (Remote) type (Note 3)	●	●	●
					0	1									Meter size ½"(15mm)	●	●	-
					0	2									1"(25mm)	●	●	-
					0	3									1¼"(32mm)	●	●	-
					0	4									1½"(40mm)	●	●	-
					0	5									2"(50mm)	●	●	-
					0	6									2½"(65mm)	●	●	-
					0	8									3"(80mm)	●	●	-
					1	0									4"(100mm)	●	●	-
					1	2									5"(125mm)	●	●	-
					1	5									6"(150mm)	●	●	-
					2	0									8"(200mm)	●	●	-
					2	5									10"(250mm)	●	●	-
					3	0									12"(300mm)	●	-	●
					3	5									14"(350mm)	●	-	●
					4	0									16"(400mm)	●	-	●
					4	5									18"(450mm)	●	-	●
					5	0									20"(500mm)	-	-	●
					6	0									24"(600mm)	-	-	●
							A								Connection flange standard ASME B 16.5 class 150	●	●	●
							J								JIS B 2220 10K	●	●	●
								N							Lining Polyurethane(PU) with NSF approval	●	-	-
								U							Polyurethane(PU) (Note 2)	○	-	-
								F							FEP	-	●	-
								P							PTFE (Note1)	-	-	●
									B						Electrode Material 316L stainless steel	●	-	-
									F						Hastelloy C (Equivalent)	-	●	●
															Flow and calibration velocity range			
										A					1.0 to 32.8 ft/s(standard range calibration)	●	●	●
										B					1.0 to 32.8 ft/s(specified range calibration)	○	○	○
										C					0.3 to 32.8 ft/s(specified range calibration)	○	○	○
															Cable glands and cFMus			
										H					1.0 to 32.8 ft/s(standard range calibration)	●	●	●
										J					1.0 to 32.8 ft/s(specified range calibration)	○	○	○
										K					0.3 to 32.8 ft/s(specified range calibration)	○	○	○
															Standard	●	●	●

Code explanation... ●: Standard ○: Option —: Not available

Note1: The grounding rings are provided to PTFE Lining, which material is 316 stainless steel and gasket material is EPDM rubber.

Note2: Meter size of Polyurethane (PU) is from 1/2"(15mm) to 16"(400mm).

Note3: Potting kit is available for submersible option when selecting separate (remote) type with PU lining.

Please consult Toshiba for details.

Table 7. Specification Code for converters

Model					Specification Code										Contents	LF620 type	LF622 type
1	2	3	4	5	6	7	8	9	10	11	12	13	14				
L	F	6	2												Electromagnetic flowmeter converter		
				0											Combined (Integral) type	●	—
				2											Separate (Remote) type	—	●
					A										Purpose		
					F										cFMus class I, Division 2 non-approved	○	○
															cFMus class I, Division 2 approved	●	●
						A									Shape		
															Standard type with case	●	●
							A								Converter mounting fitting		
							C								None	●	○
							E								Panel, Accessory for wall mounting (BNP material: SUS304)	—	●
															Accessory for pipe installation (BNP material: SUS304)	—	○
								2							Digital input/output		
															Digital output points 2 (DO1+DO2) +Digital input point 1 (DI)	●	●
									1						Current output and Communication function(Note1)		
									2						Current output + HART communication	●	●
									3						PROFIBUS communication	○	○
															Current output + Modbus (RS485) communication	○	○
										1					Power supply(Note2)		
										2					100Vac-240Vac 50/60Hz , 110Vdc	●	●
										3					24Vdc	○	○
															110Vdc	○	○
											E				Instruction manual		
															English	●	●

Code explanation... ●: Standard ○: Option —: Not available

Note 1: When PROFIBUS communication is provided, current output(4-20mA) and HART communication cannot be used.
 When Modbus communication is provided, digital output points 1(DO1) and digital output points(DO2), digital input point 1(DI), HART communication cannot be used.
 Refer Table 8 for more details.

Note2: Select 110Vdc for test report inspected under the condition of 110Vdc.

Table8. Communication functions and output selection table

Selection of Function		Availability of outputs			
Code (10 th digit)	Selected Communication	4-20mA dc	DO1	DO2	DI
1	HART	✓	✓	✓	✓
2	PROFIBUS	X	✓	✓	✓
3	Modbus	✓	✓ (Note)	X	X

Code explanation: ✓:Available X:Not Available

Note: When digital output 1 function and Modbus communication function are used at one time, TG (signal ground) of the Modbus communication function cannot be connected (2 line connection).

ISO9001 and ISO14001 are certified.

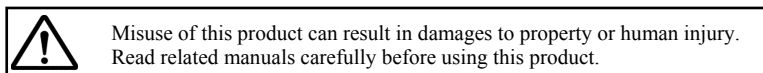

M.A. Selmon Company, Inc
 4 Oxford Rd.
 Milford, CT 06460
 203-377-3525