

TOSHIBA | Field Intelligent Device Series
**Capacitance Type Electromagnetic
 Flowmeter**

**LF511/LF541
 LF516/LF546
 1" to 4" (25 to 100 mm)**

Introduction

The capacitance type Electromagnetic flowmeter, model LF511/LF541(LF516/LF546) employs the surface electrode system outside the alumina ceramic tube, therefore, the electrodes do not come in contact with the process fluid. Its unique technology and mechanical design make it available for use not only on conventional applications but also on new applications such as low conductivity, abrasive and high concentration slurry.

The electromagnetic flowmeter uses Faraday's Law of electromagnetic induction to measure the process flow. The device consists of two units: a detector, through which the fluid to be measured flows and in which low-level signals proportional to flow rates are obtained; and a converter, which supplies excitation current to the detector, and amplifies the signals from the detector and then processes and converts the signals into the 4-20mA dc current signal.

The LF511(LF516) detector can mount with the LF541(LF546) converter as combined type.

The alumina ceramic tube for LF511(LF516) detector is highly resistant to extreme temperatures and negative pressure.

The multi-functional LF541(LF546) converter equipped with its patented **Noise-Sentry** Original noise-suppression circuit and advanced algorithms. Therefore, this flowmeter is highly resistant to noise and provides a stable output even for fluids containing slurries.

HART*¹ communicator can be used to communicate with the flowmeter from a remote place. PROFIBUS-PA*² is available as an option.

*1: HART protocol (Highway Addressable Remote Transducer) is a communication protocol for industrial sensors recommended by the HCF (HART Communication Foundation).

** DevComm2000 Smart Device Communicator available for performing HART device configurations on PC or laptop is available through the supplier.

*2: PROFIBUS is the communications protocol for factory and process automation that the PROFIBUS Organization recommends. Instead of analog control with a conventional analog signal (4-20 mA), it is fieldbus which digitizes all signals. Flowmeters support PROFIBUS-PA.

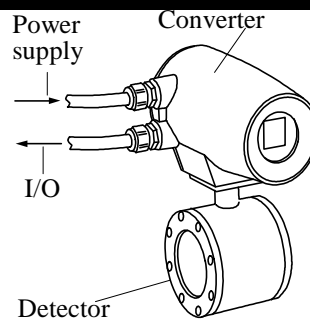

**Combined type
 LF511/LF541
 LF516/LF546**

Figure 1. Configuration



**Figure 2. LF511/LF541
 LF516/LF546**



Certification number Z01207

Specifications

Overall Specifications

Measurement range in terms of flow velocity:

1.64ft/s to 32.8ft/s(0.5m/s to 10m/s)

Accuracy: See the following table.

Flow rate as a percent of range	Accuracy	
	1.64 – 3.28 ft/s (0.5 – 1.0 m/s)	3.28 – 32.8 ft/s (1.0– 10 m/s)
0 – 50%		+/- 0.25 %FS
50 – 100%	+/- 0.5 %FS	+/- 0.5 % of rate

Note: The accuracy above is measured under standard operating conditions using the weighing method at Toshiba's flow calibration facility.

Fluid conductivity: 0.01 μ S/cm minimum

Note 1: Refer to the following relationship between conductivity and fluid velocity.

Note 2: Please contact Toshiba before ordering when the fluid conductivity is under 0.1 μ S/cm.

Trial test is highly recommended for the application under 0.1 μ S/cm.

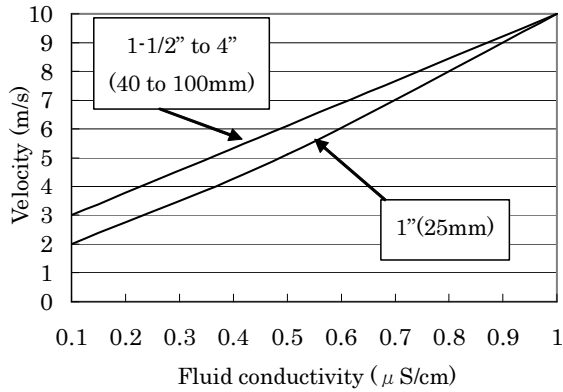

Fluid temperature:

14 to 248 °F (- 10 to 120 °C)

Ambient temperature:

14 to 122 °F (-10 to 50 °C)

Note: Contact Toshiba before ordering when the ambient temperature is over 122 °F (50 °C).

Structure: IP67 and NEMA 4 Watertight

Power consumption: approximately 15W(24VA)

Approved hazardous location certification:

Model: LF516/LF546

cFMus Nonincendive for use in

hazardous (classified) locations:

Class I, II, III, Division 2, Groups A-G

Detector and converter combination:

LF511/LF541: Combined type for standard specification.

LF516/LF546: Combined type with Ex approval of Class I, II, III, Division 2 (cFMus).

■ **Model LF511 and LF516 Detector**

Mounting style: Wafer type

Fluid pressure: -15 to 300psi, or -1.0 to 20 bar (-0.1 to 2.0MPa)
(Depending on each flange standard)

Note: The test pressure before shipping from the factory is equal to twice the nominal pressure rating of the customer specified flange connection for duration of 5 minutes.

Connection flange standards:

ASME B16.5 class 150, ASME B16.5 class 300

EN1092-1 PN10, EN1092-1 PN16

JIS B 2220 10K, JIS B 2220 16K, JIS B 2220 20K

Principal materials:

Case — Stainless steel

Linings — Alumina Ceramic tube

Grounding rings — 316 stainless steel (std.)

Note: See Table 3 for optional materials and other related information.

Coating — no coating (stainless steel body)

Heat shock resistance — for a ceramic tube detector

Heating: $\Delta T \leq 302$ °F /0.5sec (150 °C /0.5sec)

Cooling: $\Delta T \leq 212$ °F /0.5sec (100 °C /0.5sec)

Note: The above means that the ceramic tube detector withstands the shock of sudden heating (temperature difference **302°F** or less per 0.5seconds) and sudden cooling (temperature difference **212°F** or less per 0.5seconds).

Dimensions and weights: See Figure 3.

■ **Model LF541 and LF546 Converter**

Input signals

Digital input DI

Signal type: 20 to 30Vdc voltage signal

Input resistance: 2.7 k Ω

Number of inputs: one point

DI function — One of the following functions can be assigned to the DI signal.

Range switching — Selects either the higher or lower range in the unidirectional or bidirectional 2-range setting.

Totalizer control — Start/Stop and Reset/Start operation in built-in totalizer

Fixed-value outputs — Outputs fixed-values for current and pulse outputs.

Zero adjustment — Executes zero adjustment (on-stream at zero flow rate).

Output signals

Current output:

4-20mAdc (load resistance 0 to 750 Ω)

Digital outputs — 2 points are provided as standard.

Digital output DO1:

Output type: Transistor open collector

Number of outputs: One point

Output capacity: 30Vdc, 200mA maximum

Digital output DO2:

Output type: Solidstate relay output (non polarity)

Number of outputs: One point

Output capacity: 150Vdc, 150mA maximum or 150 Vac (peak to peak), 100mA maximum

DO1 and DO2 functions — One of the following functions can be assigned.

• **Pulse output (available only for DO1)**

Pulse rate: 3.6 to 10,800,000 pulses/hr

Pulse width: 0.3 to 500ms (but less than half of the period for 100% flow rate)

- **Multi-range selection outputs (Note 1)**
- **High-high, high, low and/or low-low limit alarm outputs (Note 2)**
- **Preset count output**
- **Converter failure alarm output (Note 2)**

Note 1: Two outputs (DO1 and DO2) are needed for 4-range switching and forward/reverse 2-range switching.

Note 2: Normal Open (default set) or Normal Close is selected for alarm outputs when programming.
When power failure occurs, unit will be fault to Normal Open.

Communications output

- **HART (std.)** — Digital signal is superimposed on 4–20mA dc current signal as follows:
 - Conforms to HART protocol
 - Load resistance : 240 to 750 Ω
 - Load capacitance : 0.25 μ F maximum
 - Load inductance : 4 mH maximum
- Note:** HART (Highway Addressable Remote Transducer) protocol is a communications protocol for industrial sensors recommended by HCF (HART Communication Foundation).

PROFIBUS communication:

Protocol: PROFIBUS-PA
 Baud rate: 31.25kbps
 Bus voltage: 9-30VDC
 Consumption electric current of bus: less than 16mA
 Manufacture Ident-No.: 093B_{HEX}
 Standard Ident-No.: 9740_{HEX}
 Slave address: 0-126 (Default address is 126)
 Profile: Profile Ver.3.01 for Process Control Devices

Function blocks: AI(Flow) \times 1 , Totalizer \times 1

Note: When the PROFIBUS communication specification is selected, current output signals (DC4-20mA) are not available.

LCD display: 128x128 full dot-matrix LCD display (back-light provided)

A parameter change will rotate the display.

Parameter settings: Parameters can be set by infrared ray switches at the LCD board. The AF900 hand-held terminal is available for setting parameters from remote places.

Note: Products are shipped in such a status where major parameters that affect flow measurement may not be set and changed in advance for sealing specification.

Note: When the PROFIBUS communication specification is selected, the handheld terminal AF900 is not available.

Counter control: If the digital input is set for counter control, counter control is available for the integrated value and the pulse output.

Zero adjustment: Zero point adjustment can be started by pressing the switch in the converter.

Damping: 1 to 200 seconds (selectable in 1 second increments)

Damping: 1 to 200 seconds (selectable in 1 second increments)

“Field re-verification” Mag-Prover – Toshiba’s Zero span calibration tools allows unit to be re-calibrated and verified using an internal software program (For more information contact Toshiba International Corp.)

Conditions when power fails:

Parameter setting values are stored in non-volatile memory and the values will be restored when the power returns to normal condition. The outputs and display will remain as follows when power fails.

- Current output: 0 mA
- Digital output: OFF
- LCD display: No display

Power supply:

- 100 to 240Vac, 50/60Hz
(allowable voltage 80 to 264Vac)

Surge protection: Arresters are installed in the power supply and current signal output circuit to help protect the meter from lightning and improve personnel safety.

Case: Aluminum alloy

Coating: Acrylic resin-baked coating, pearl-gray colored

Cable connection ports:

Cable glands —

LF511/LF541 without cFMus Approval:
 Provided as standard, G(PF) 1/2 female threads, Nylon 66 material.

LF516/LF546 with cFMus Approval:
 Not provided, 1/2-14NPT male threads are required.

Applicable diameter — 0.433 to 0.512 inch.
(11 to 13mm)

Note: The compatible outer diameter of the signal cable glands is ϕ 6 to 8mm for the one equipped with the PROFIBUS communication function. The power cable glands have the same compatible outer diameter (ϕ 11 to 13mm) as the standard size. Give a separate instruction if you need one with the standard compatible outer diameter (ϕ 11 to 13mm) for signal cable glands.

Vibration resistance:

No resonance to the following levels of vibration:

- 10 to 150Hz with acceleration of 9.8m/s²
- Vibration of 30Hz with 29.4m/s² in 2h in each direction will not cause any defect to unit..

Note: Avoid using the flowmeter in an environment with constant vibration

MTBF:

110,000 hours at 77 °F (25 °C) based on MIL-HDBK-217F

Terminal block: 10 poles (M4 screw)

Installation

■ **Dimensions**

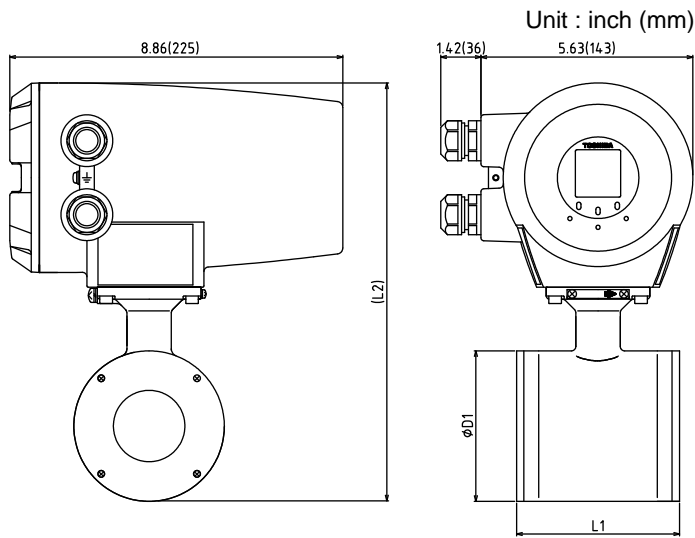

ASME B 16.5 class 150 and class 300 dimensions:

Meter size (inch)	L1 (inch)	(L2) (inch)	D1 (inch)	Weight (lb)
1"	3.15	8.43	2.60	Approx. 12
1-1/2"	3.94	10.39	3.35	Approx. 14
2"	4.33	11.02	4.02	Approx. 16
3"	4.33	12.05	5.00	Approx. 18
4"	7.09	13.31	6.26	Approx. 29

JIS B 2220 10K and 16K and JIS20K dimensions:

Meter size (mm)	L1 (mm)	(L2) (mm)	D1 (mm)	Weight (kg)
25	80	241	66	Approx. 5
40	100	264	85	Approx. 6
50	110	280	102	Approx. 7
80	110	306	127	Approx. 8
100	180	338	159	Approx. 13

Note: 1 inch = 25.4mm

Note1: Cable glands are not provided for LF516/LF546 of cFMus approved type.

Refer the details from the description of cable connection ports at page3 of this document..

**Figure 3. LF511/LF541 and LF516/LF546 Combined type flowmeter
Meter sizes 1" (25mm) to 4" (100mm)**

External Connections

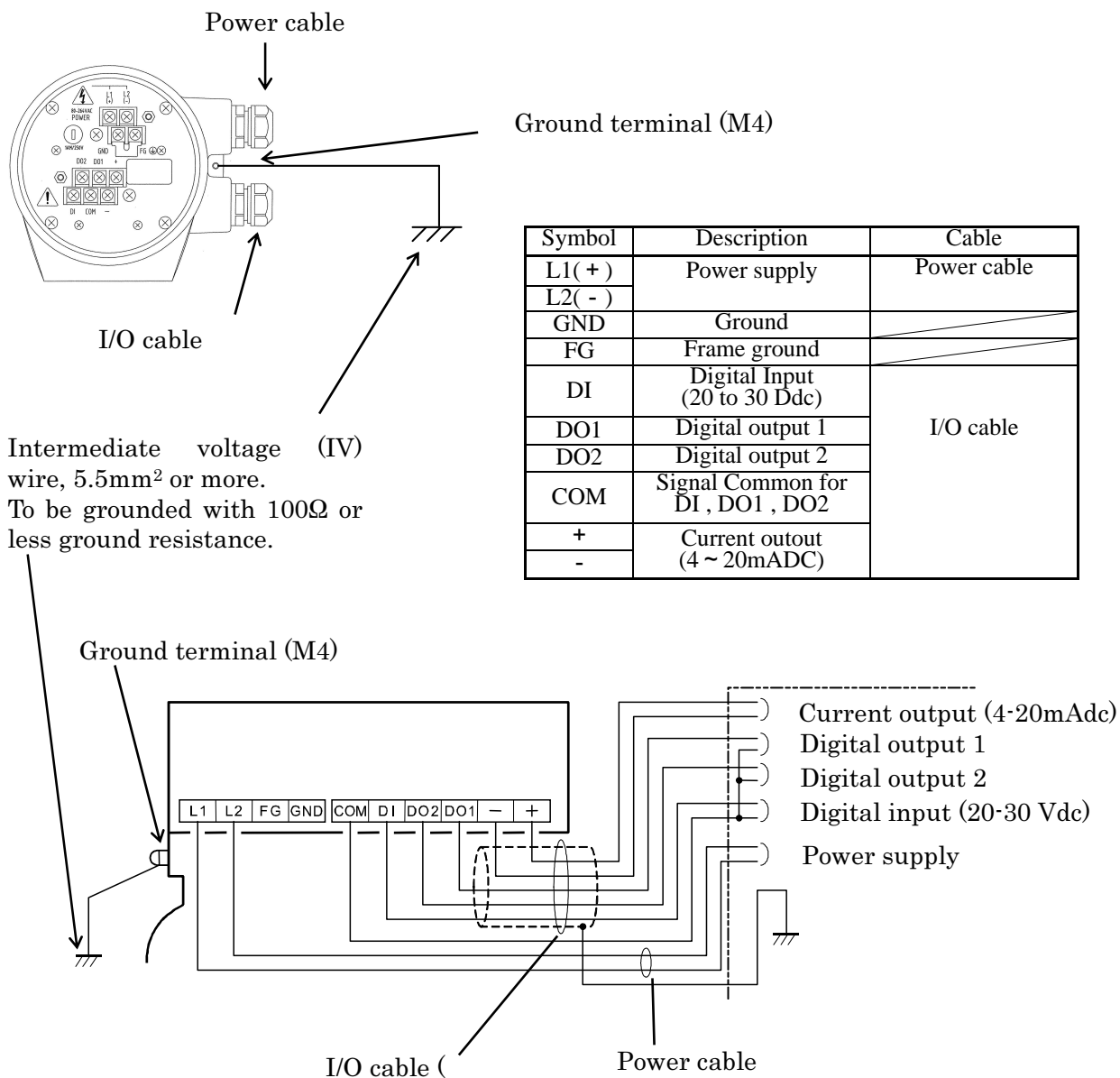

Figure 4. LF511/LF541 and LF516/LF546 flowmeter Wiring Diagram

■ Piping Precautions

- (1) Design the LF511/LF541 and LF516/LF546 piping to keep the filled condition inside the pipe.
- (2) The electromagnetic flow meter detector LF511-type and LF516-type does not have a loose mechanism. Place a loose short pipe if required.
- (3) The LF511/LF541 and LF516/LF546 requires the following straight pipe length for both upstream and downstream.

Upstream	90 degree bent pipe, T-tube, reducer or full admission condition using slice valve	L=5D
	Other valves	L=10D
Downstream	Unless the valve comes into the pipe of detector	L=0

L: Required straight pipe length -----
 Straight pipe length plus half length of detector.
 D: Nominal diameter.

- (4) Design piping so that the liquid pressure does not exceed the standard flange pressure.
- (5) Select one from the size, length and quantity of the compatible bolts and nuts are different depending on the bore diameter and the flange specification.
- (6) Insulate piping so that the temperature around the transformer may not exceed 50°C when the high-temperature fluid passes.

■ Wiring Precautions

- (1) Connect the grounding wire (IV wire 5.5mm² or more) to a good earth ground (100 ohm or less ground resistance). Make the wire as short as possible. Do not use a common ground shared with other equipment where earth current may flow. An independent earth ground is recommended.
- (2) DO1, DO2, and DI use the same common terminal (COM). This COM cannot be connected to other equipment which have their own ground terminal.
 (Power supply for connecting to DI or DO, etc...) Need to wire separately.

■ Meter Size

To select the meter size:

See Table 1 to 2 and find meter sizes within the velocity of 1.64 to 32.8 ft/s (0.5 to 10 m/s) for a specified full-scale (measuring range high limit) flow.

- When the fluid conductivity is 1 uS/cm or smaller, the maximum flow velocity becomes 32.8 ft/s (10 m/s) or slower. Need to confirm its availability by

referring to this Table..

- Make sure the full-scale flow rate used for the final planning stage stays within 32.8 ft/s (10 m/s) in terms of flow velocity.

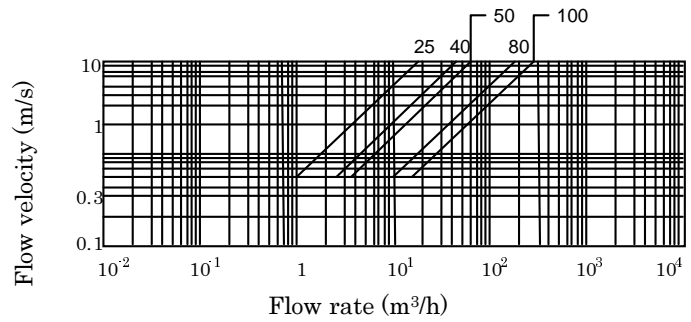

Table 1. Flow rate and Flow velocity (English Unit)
 Unit: gal/min

Meter size	Flow rate		
	1.64 ft/s	3.28 ft/s	32.8 ft/s
1	3.900	7.780	77.80
1-1/2	9.953	19.91	199.1
2	15.55	31.12	311.2
3	39.81	79.65	796.5
4	62.22	124.5	1245

Table 2. Flow rate and Flow velocity (SI Unit)
 Unit: m³/h

Meter size (mm)	Flow rate		
	0.5 m/s	1 m/s	10 m/s
25	0.884	1.767	17.67
40	2.262	4.523	45.23
50	3.534	7.067	70.67
80	9.045	18.09	180.9
100	14.14	28.27	282.7

Ordering Information

1. When ordering the LF511/LF541 and LF516/LF546 flowmeter, refer to Tables 3 and 4 (Type Specification Codes).
An entry must be made for each of the columns in each of these tables.
2. Fluid characteristics:
 - (1) Type of fluid to be measured and its characteristics
 - (2) Fluid temperature
 - (3) Fluid pressure
 - (4) Electrical conductivity of the fluid
3. Measuring range
4. I/O function setting
5. Ordering scope:
Flow calibration data: (required or not)
6. Other items:
Specifications other than standard items

Consult Toshiba before ordering when choose material of grounding ring.

Table 3. Specification Code (Capacitance type detector LF511 and LF516 Series)

Model					Specification Code									Description	Category	
1	2	3	4	5	6	7	8	9	10	11	12	13	14			
L	F	5	1	1											Detector of Capacitance type Electromagnetic Flowmeter	
L	F	5	1	6											cFMus Hazardous location certification type (Note 5)	
						E									Meter size	●
						F									1" (25mm)	●
						G									1 1/2" (40mm)	●
						H									2" (50mm)	●
						J									3" (80mm)	●
						L									4" (100mm)	●
							L								Mounting Style	
															Detector/Converter combined type	●
															(LF511/LF541) (LF516/LF546)	
								C							Connection flange standard (Note 1)	●
								D							ASME B 16.5 class 150	●
								G							ASME B 16.5 class 300	●
								H							EN 1092-1 PN 10	●
								J							EN 1092-1 PN 16	●
								K							JIS B 2220 10K	●
								L							JIS B 2220 16K	●
								Z							JIS B 2220 20K	●
															Other (Note 2)	○
									A						Application	
															Standard	●
										A					Lining Material	
										B					Alkali-resistant ceramic (standard) (Note 3)	●
															Acid-resistant ceramic (Note 3)	○
											C				Grounding Ring Material (Note 4)	
											D				316 stainless steel (standard)	●
											E				316L stainless steel	○
											H				Ti (titanium)	○
											Z				Hastelloy C (Equivalent)	○
															Other (Note 2)	○
												D			Flow and calibration velocity range / with or without designated setting item	●
												E			Standard range calibration / without designated setting item	○
												F			Specified range calibration	○
															Standard range calibration / with designated setting item	○
													A		Excitation and Signal Cables	
															None	●
															Coating	
														A	No coating	●
														Z	Other (Note 2)	○

Code explanation: ●: Standard, ○: Option

Note1: Same shape of flange standard among ASME B 16.5 class 150 and ASME B 16.5 class 300, EN 1092-1 PN10, EN 1092-1 PN 16, , JIS B 2220 10K, JIS B 2220 16K, and JIS B 2220 20K.

Note2: In case of cord "Z" , please refer beforehand.

Note3: The type of material used is alumina ceramic, this is suitable for both acid and alkali liquids.

This ceramic lining is held with seals, there are two types, one for acids, and the other for alkalis.

Note4: Consult Toshiba before ordering when choosing materials at the wetting parts.

Note5: Cable glands are not provided. Refer to the part of "Cable connection port) at detector and converter.

Table 4. Specification Code for Converter

Model					Specification Code									Description	
1	2	3	4	5	6	7	8	9	10	11	12	13	14		
L	F	5	4	1											Combined Converter of Capacitance type Electromagnetic Flowmeter
L	F	5	4	6											Combined Converter of Capacitance type Electromagnetic Flowmeter with cFMus Hazardous location certificate
					A										Usage General purpose
						A									Mounting Structure Detector/Converter combined type
							B								Display LCD display provided
								2							Output 4-20mAdc current, 2 points DO and 1 point DI provided.
									1						Communications function Current output + HART communication PROFIBUS communication (Note1)
										2					
											1				Power supply 100 to 240Vac, 50/60Hz
												A			Coating Acrylic resin-backed coating, pearl-gray colored
												Z			Other (option)
													A	A	Standard

Note 1: When PROFIBUS communication is provided, current output(4-20mA) and HART communication cannot be used.
Refer Table 5 for more details.

Table5. Communication functions and output selection table

Selection of Function		Availability of outputs			
Code (10 th digit)	Selected Communication	4-20mAdc	DO1	DO2	DI
1	HART	✓	✓	✓	✓
2	PROFIBUS	X	✓	✓	✓

Code explanation: ✓:Available X:Not Available

ISO9001 and ISO14001 are certified.

	Misuse of this product can result in damages to property or human injury. Read related manuals carefully before using this product.
---	--

M.A. Selmon Company, Inc
 4 Oxford Rd.
 Milford, CT 06460
 203-377-3525